

The Genuine. The Original.



# HYDRAULIC DOCK LEVELER

## SPECIFICATIONS

### DIMENSIONS/CAPACITY/APPLICATION

Model H68R	6' wide x 8' length
Model H78R	7' wide x 8' length
Weight Capacity	30,000, 35,000, 40,000, 45,000 lbs CIR
Ideal Application	High-volume, fast-paced docks
Option	24" Pit Adaptation Kit

### BUMPER BOXES STANDARD

Molded Rubber Bumpers	√ Standard
Laminated Bumpers & Steel Faced Bumpers	Optional

### CONTROL

Control Panel (Single Button)	√ Standard
-------------------------------	------------

### LIP

16" Lip	√ Standard
18" & 20" Lip	Optional
Lip Keepers & Lip Bevel	√ Standard
Lip Taper	√ Standard (Model H78R Only)

### OPERATION

End Loading & Below Dock Capable	√ Standard
Hydraulic Pump: 3 Phase 208V, 240V, 480V	Optional
Hydraulic Pump: Single Phase 120V, 208V, 240V	Optional

### SAFETY

Tethered Maintenance Brace	√ Standard
Safety Tread on Deck & Lip	√ Standard
Velocity Safety Fuse	√ Standard
Toe Guards: Working Range (12" Above/Below Dock)	√ Standard
Toe Guards: Full Operating Range	√ Standard

### WEATHER SEALS

Weather Seal: Brush or Neoprene	Optional
---------------------------------	----------



### 1-Year Limited Warranty.

Warranty on dock equipment extends to **2-year limited when paired and purchased with the door.**

## SAFE Features.

Designed with safety at the forefront, the Overhead Door™ hydraulic dock leveler features an open pit base frame providing clear access for safer installation, easier cleaning, and streamlined maintenance—protecting crews and preserving uptime.

- Targeted shimming reduces setup effort and enhances safety



**Patent-pending textured powder coat** delivers unmatched slip resistance and preserves finish in high-traffic environments



**Open lug hinge design** sheds debris and requires minimal lubrication, keeping lip and deck movement smooth and maintenance simple

## SMOOTH Transitions.

Built to perform under pressure, the Overhead Door™ hydraulic dock leveler consistently delivers on smooth, secure transfers year after year—maximizing operational efficiency.

- Meets ANSI MH30.1-2022 standards for strength and durability—proven to support a 10-year structural life



**34% weld coverage** between beam and deck offer industry-leading reinforcement for long-term reliability



**Standard 3-wheel fork truck support** expands application versatility—ready for diverse loading demands

## SMART Designs.

Thoughtful engineering—like four steel fork loops to improve stability and prevent sliding when stacked for transport—speeds up install time, simplifies upkeep, and reduces service calls.

- Top side adjusters quickly align the deck with the building floor for a faster install
- Full-width rear deck hinge enhances structural integrity



**Unique fillet welds** create a stronger bond to pit steel and speed up installation—reducing labor time without compromising structural integrity



**Working range toe guards** are easily replaced without welding—simplifying service and minimizing downtime

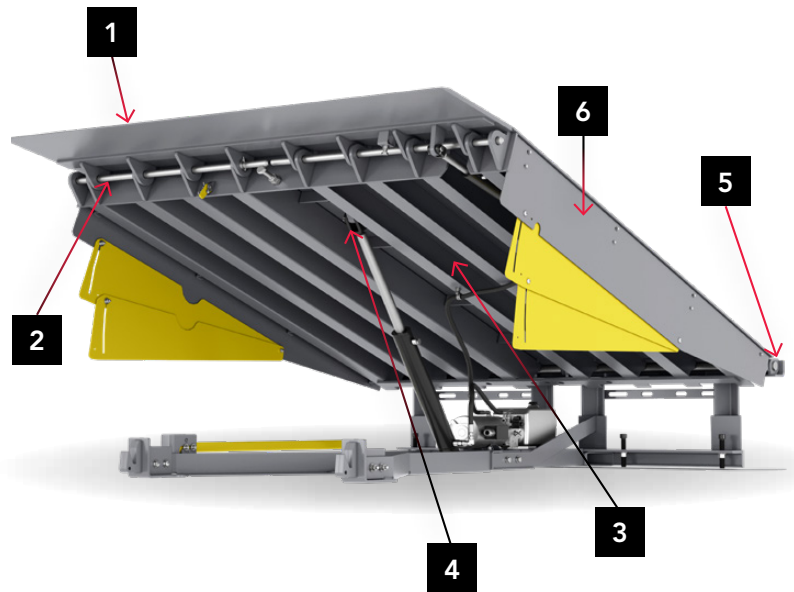

©2026 Overhead Door Corporation. Overhead Door is a trademark and the Red Ribbon logo is a registered trademark of Overhead Door Corporation. All other trademarks are the property of their rightful owners. Consistent with our policy of continuing product improvement, we reserve the right to change product specifications without notice or obligation.