

# The Genuine. The Original.



## SITE SURVEY

### PIT LEVELER, EDGE OF DOCK LEVELER, RESTRAINT, SEALS AND SHELTERS

CONTACT: \_\_\_\_\_ PHONE: \_\_\_\_\_

TITLE: \_\_\_\_\_ FAX: \_\_\_\_\_

ADDRESS: \_\_\_\_\_

CITY: \_\_\_\_\_ STATE / ZIP: \_\_\_\_\_

DATE	COMMENTS

1. Please complete all survey questions relevant to the equipment being quoted. Survey must be completed based upon conditions at time of installation.

- **Always complete pages 1-2.**
- For Dock Levelers, complete pages 3-8.
- For Vehicle Restraints, complete pages 4, 6, 8, 10.
- For Electrical Control Panels, complete page 9.
- For Dock Seals / Shelters, complete page 3, 4, 6, 8.
- For any miscellaneous notes or job-specific information not provided elsewhere, complete page 11.
- Pictures of equipment and operating environment recommended with the survey.

**For any application where approach is inclined / declined, dock leveler is cantilevered out from building, or vehicle restraint will be installed with dock leveler, page 8 must be completed.**

Do not leave any fields blank. If information is unavailable at the time of survey, please write "unknown" or "TBD". Information not provided may lead to a delay in quote or order processing. Overhead Door is not responsible for errors in quote or order processing due to missing information.

2. If multiple dock positions are being quoted and conditions vary from position to position, please submit a survey for each position.

3. If site and/or existing equipment pictures are available, please include them with this survey.

# SITE CONDITIONS

			COMMENTS
IS THIS A:	<input type="checkbox"/> NEW CONSTRUCTION	<input type="checkbox"/> RETROFIT	_____
IS THERE A LEVELER THAT NEEDS TO BE UNINSTALLED?	<input type="checkbox"/> YES	<input type="checkbox"/> NO	_____
IF SO, IS EXISTING LEVELER A:	STANDARD PIT	POUR-IN PAN	
DOES THE CONCRETE NEED TO BE REWORKED?	<input type="checkbox"/> YES	<input type="checkbox"/> NO	_____
DO THE CURB ANGLES NEED REPAIR?	<input type="checkbox"/> YES	<input type="checkbox"/> NO	_____
CURB ANGLE CONFIGURATION (PIECES)	<input type="checkbox"/> 3 <input type="checkbox"/> 4 <input type="checkbox"/> 6 <input type="checkbox"/> 8		

# BUILDING DATA

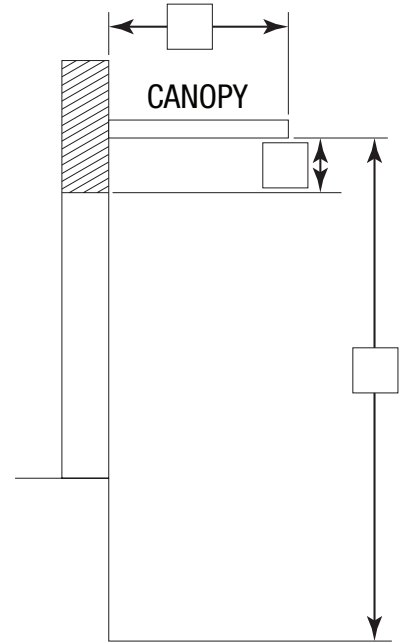
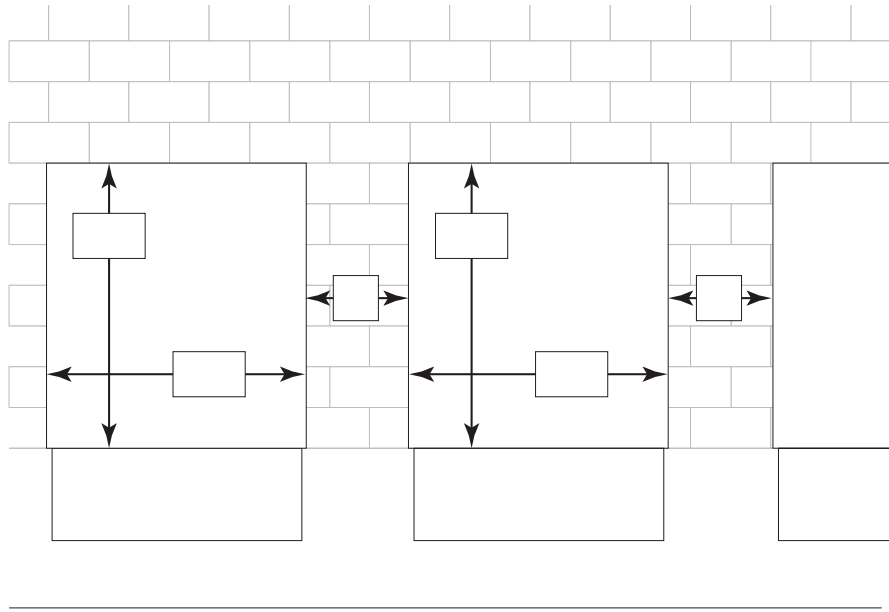

WALL CONSTRUCTION		DOOR JAMB CONSTRUCTION		DOCK FACE CONSTRUCTION	
MASONRY ___	WOOD ___	MASONRY ___	WOOD ___	CONCRETE ___	BLOCK ___
STEEL ___	INSULATED WALL ___	STEEL ___	INSULATED WALL ___	OTHER _____	
CONCRETE ___		CONCRETE ___		<b>OTHER</b>	
OTHER _____	OTHER _____	OTHER _____		DRAIN _____	LIGHTS _____
				OTHER _____	
DESCRIBE FACE OF WALL AT OPENING (TRIM, LIGHTING, ETC.)		_____			

# RESTRAINT

		COMMENTS
MODEL	_____	_____
STYLE	_____	_____
MANUFACTURER	_____	_____
IN WORKING CONDITION?	____ YES	____ NO
____ POWERED	____ MANUAL	
POWER CONDUIT LOCATION (LOOKING INTO BUILDING)	____ RIGHT	____ LEFT

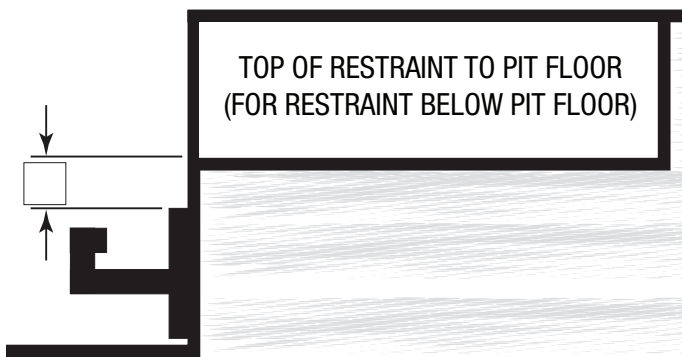

# EXISTING SEALS AND SHELTERS

		COMMENTS
EXISTING UNITS	____ YES	____ NO
MODEL	_____	
MANUFACTURER	_____	
PROPER SIZE FOR DOOR	____ YES	____ NO
SEALS OBSTRUCT LOADING	____ YES	____ NO
SEALS / SHELTERS NEED REPAIR?	____ YES	____ NO

# LOADING INFORMATION

LOADING VEHICLE TYPE	<input type="checkbox"/> MANUAL PALLET TRUCK	<input type="checkbox"/> ELECTRIC PALLET TRUCK	<input type="checkbox"/> ELECTRIC FORKLIFT	<input type="checkbox"/> GAS FORKLIFT
FORKLIFT STYLE	<input type="checkbox"/> 3 WHEEL	<input type="checkbox"/> 4 WHEEL		
LOADING VEHICLE WEIGHT	<input type="text"/> LBS.			
FORKLIFT TIRES	<input type="checkbox"/> SOLID	<input type="checkbox"/> PNEUMATIC		
MAX WEIGHT OF PALLET / LOAD	<input type="text"/> LBS.	GVWR (LOADING VEHICLE AND LOAD)	<input type="text"/> LBS.	
MAXIMUM FORKLIFT SPEED	<input type="text"/> MPH	AVERAGE FORKLIFT SPEED	<input type="text"/> MPH	
AVERAGE # OF TRUCKS PER LEVELER PER WORKING DAY	<input type="text"/>	AVERAGE ROLLOVER CYCLES PER TRUCK	<input type="text"/>	
NUMBER OF WORK DAYS PER YEAR	<input type="text"/>	IS AUTOMATED LOADING EQUIPMENT USED?	<input type="checkbox"/> YES	<input type="checkbox"/> NO
TRUCK AND TRAILER TYPES	<input type="checkbox"/> LTL	<input type="checkbox"/> FLATBED	<input type="checkbox"/> CONTAINER	<input type="checkbox"/> REFRIGERATED
	<input type="checkbox"/> HIGH CUBE		<input type="checkbox"/> STEP VAN	<input type="checkbox"/> CARGO VAN
YARD JOCKEY USAGE?	<input type="checkbox"/> YES	<input type="checkbox"/> NO		
LIFT GATES REQUIRED (PHOTOS / DIMENSIONS REQUIRED)?	<input type="checkbox"/> YES	<input type="checkbox"/> NO		

# TRUCK DATA

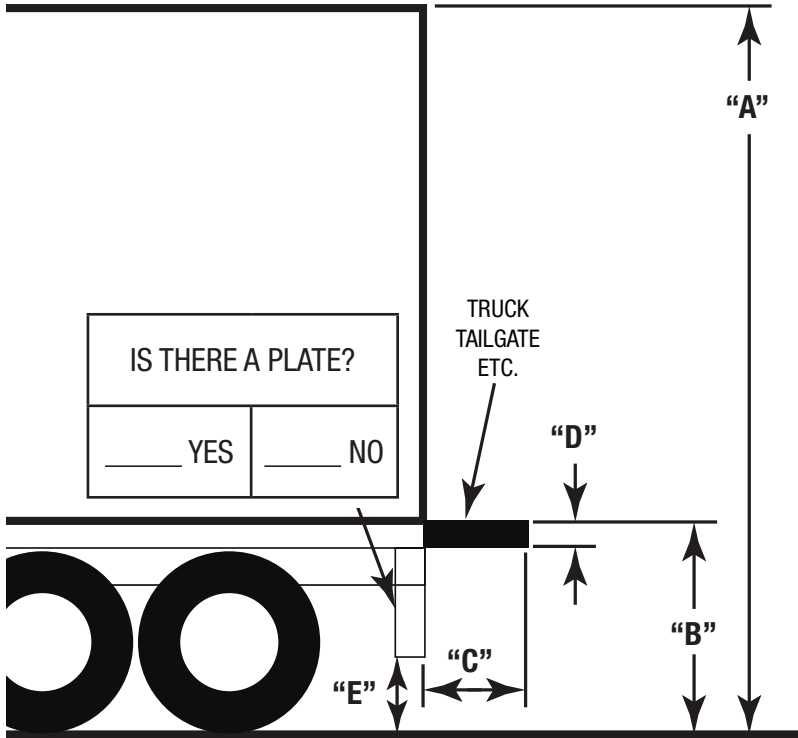

TRUCK	DIMENSIONS "INCHES"
HEIGHT "A"	_____
BED HEIGHT "B"	_____
BED WIDTH	_____
EXTENSION LENGTH "C"	_____
EXTENSION WIDTH	_____
THICKNESS "D"	_____
RIG HEIGHT "E"	_____

# EXISTING DOCK LEVELER PIT

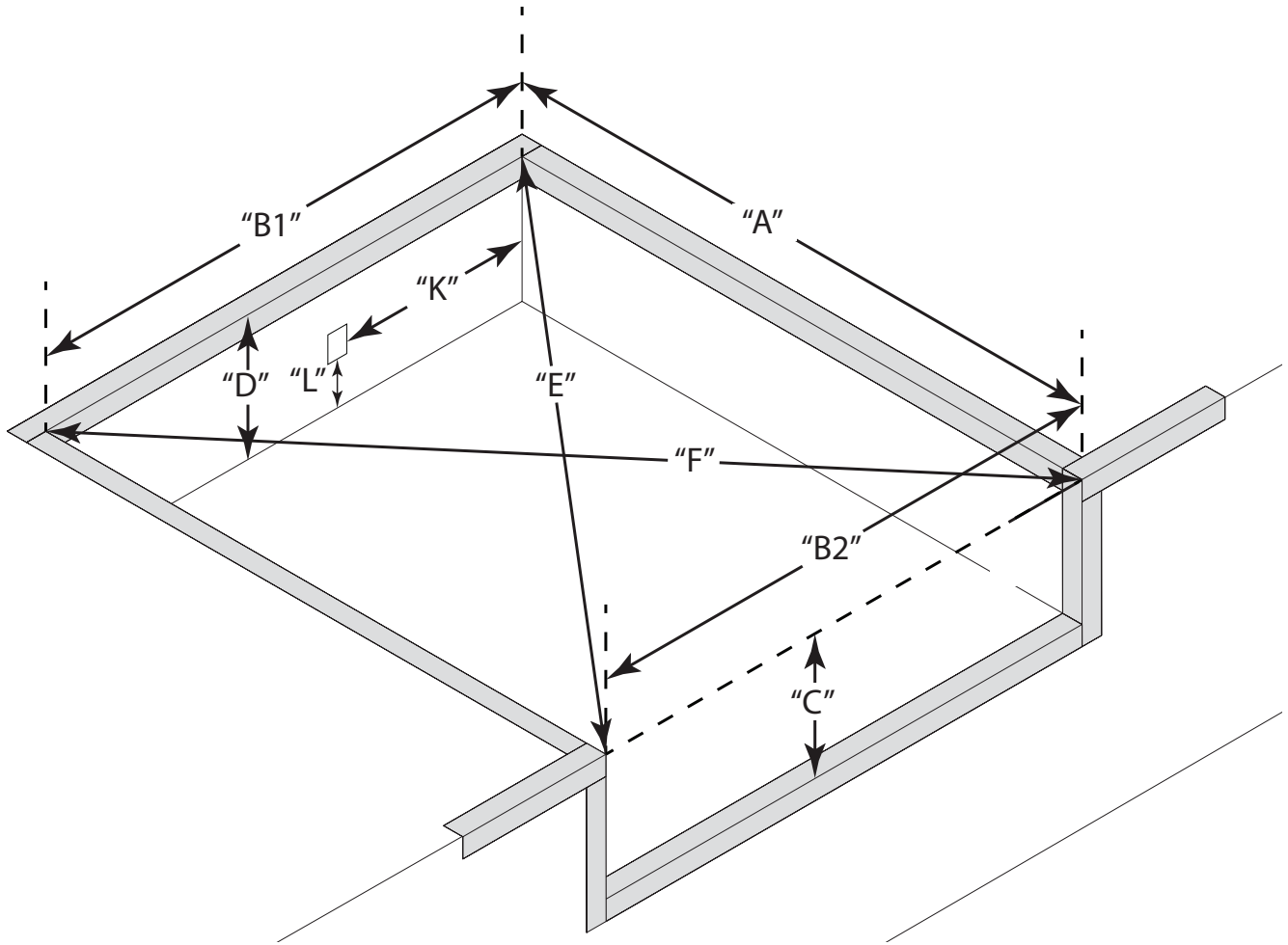

## PIT MEASUREMENTS

PIT LENGTH DIM. "A"	_____	PIT SQUARE DIM. "E"	_____
PIT WIDTH (REAR) DIM. "B1"	_____	PIT SQUARE DIM. "F"	_____
PIT WIDTH (FRONT) DIM. "B2"	_____	DIM. "K"	_____
STANDARD PIT DEPTH (FRONT) DIM. "C"	_____	DIM. "L"	_____
STANDARD PIT DEPTH (REAR) DIM. "D"	_____		

# BUILDING / DRIVE APPLICATION

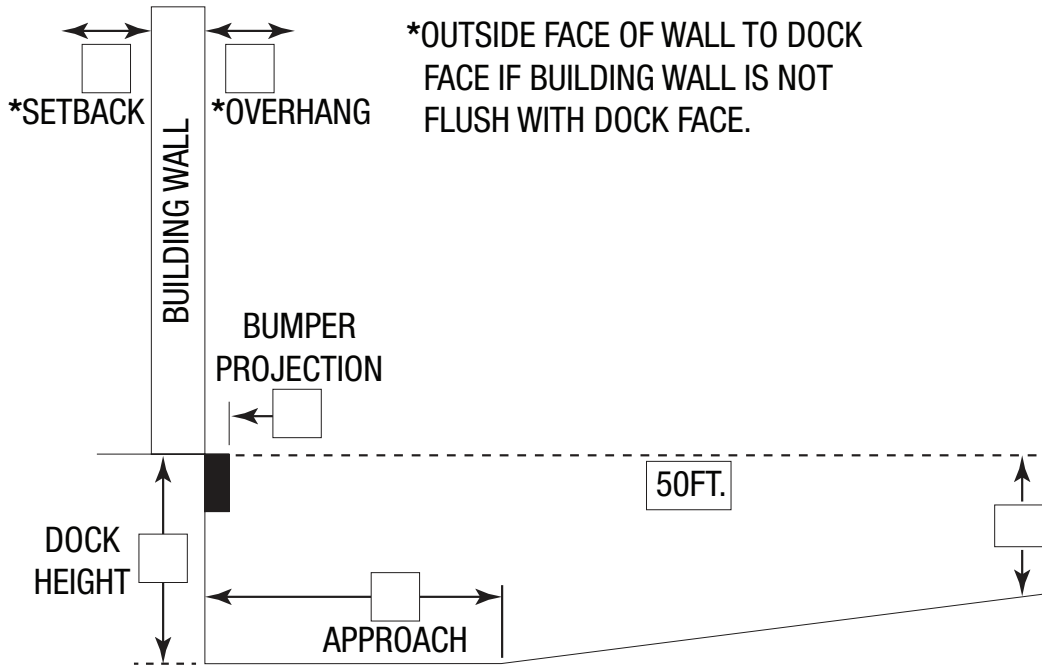

DRIVE CONSTRUCTION	CONCRETE > 8'0"	ASPHALT
OTHER (DESCRIBE BELOW) _____		

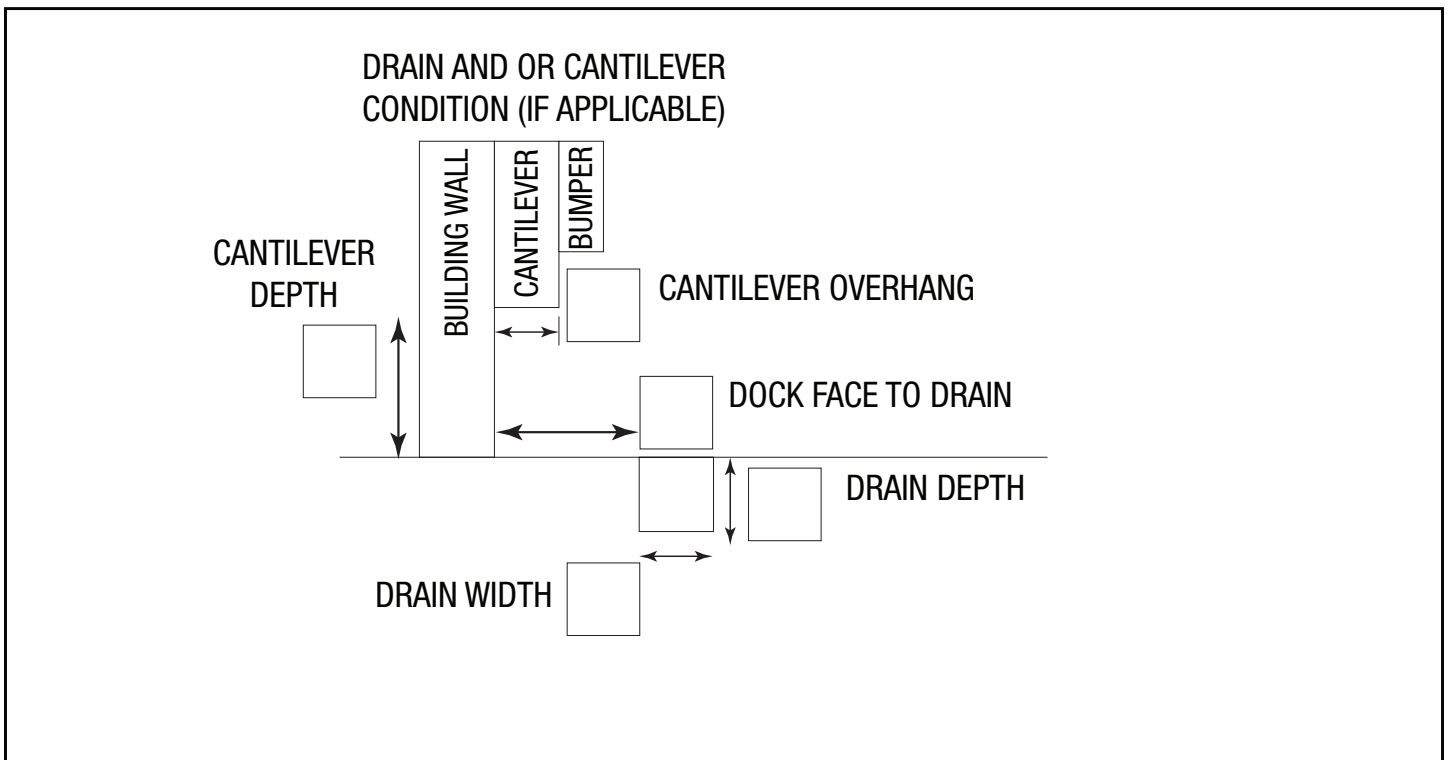



# ELECTRICAL DETAILS

LOCATION OF CONDUIT ENTERING THE PIT	
ELECTRIC AVAILABLE (VOLTAGE, PHASE, AMPERAGE)	
ARE THERE INTERLOCKS CONNECTED TO EXISTING LEVELER CONTROLLER	
ARE THERE DOCK LIGHTS CONNECTED TO EXISTING LEVELER CONTROLLER	
IS THE POWER AND DOCK LIGHT WIRING ON THE LEFT OR RIGHT HAND SIDE (LOOKING INTO THE BUILDING)	
IS THERE A POWERED DOOR?	
IS THERE A POWERED RESTRAINT?	

# EDGE OF DOCK DATA

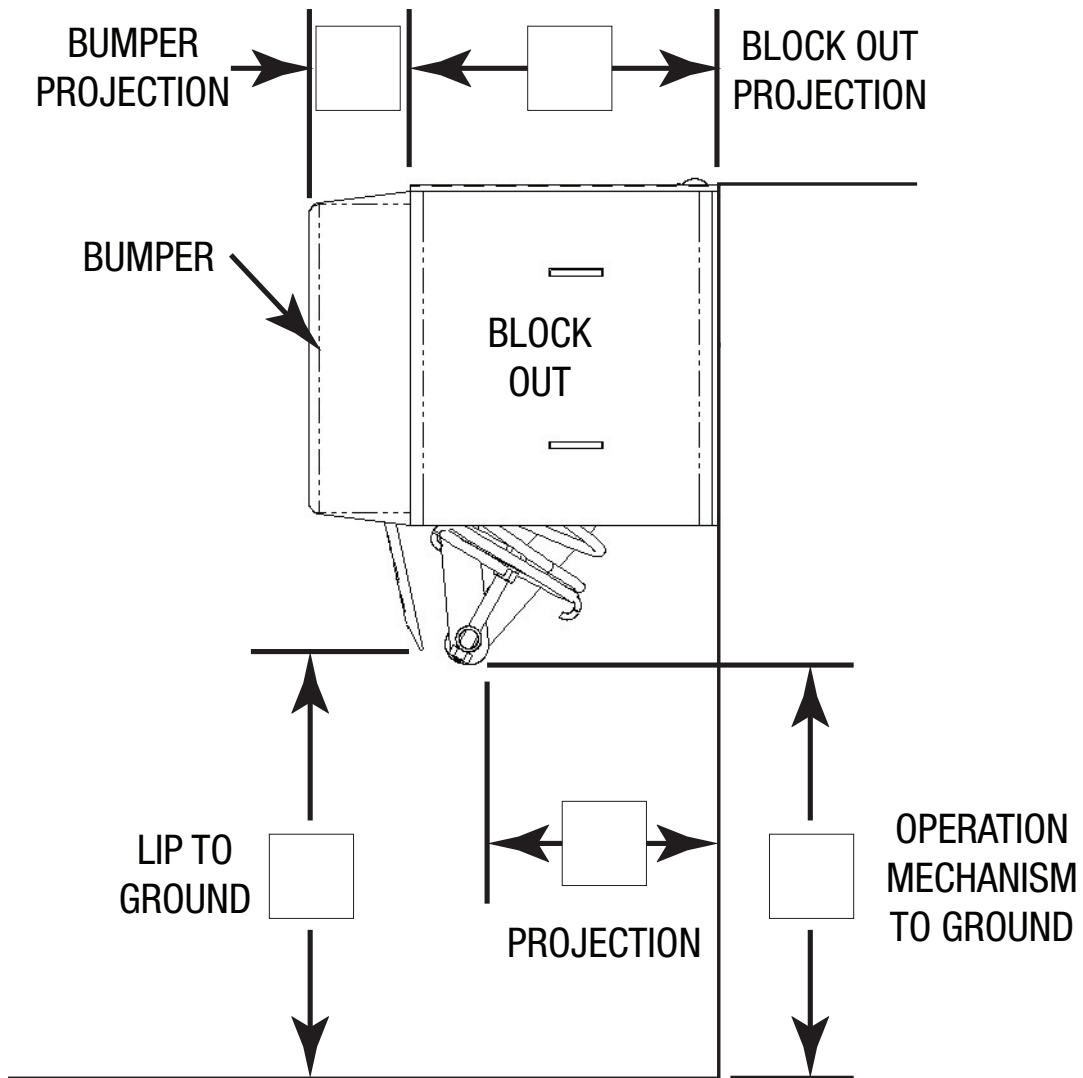
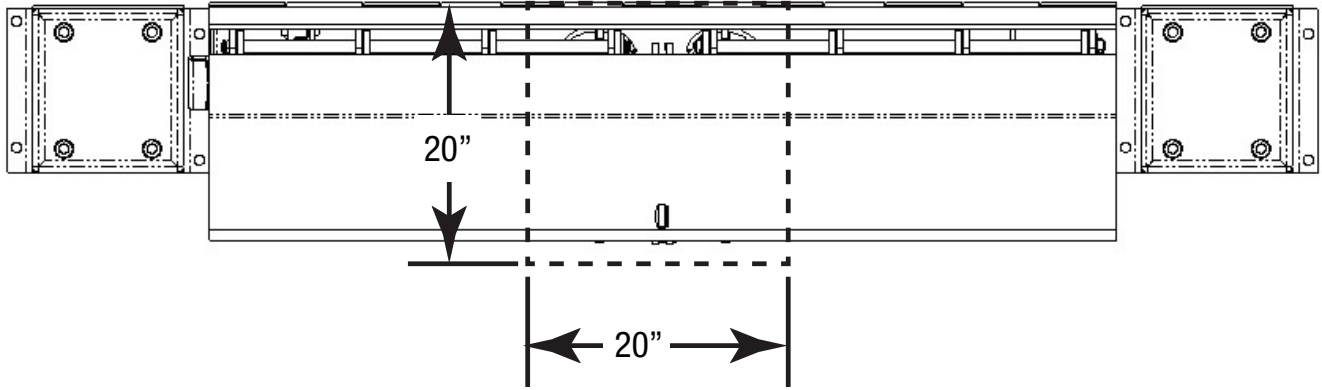

# OTHER

			COMMENTS
DOCK LIGHTS REQUIRED	____ YES	____ NO	_____
DOCK FAN REQUIRED	____ YES	____ NO	_____
WHEEL CHOCKS UTILIZED	____ YES	____ NO	_____
TRUCK STABILIZER JACK UTILIZED	____ YES	____ NO	_____