

# INTERLOCK SWITCH - TURRET LEVER ARM

PART NUMBER: 075396.0000.S

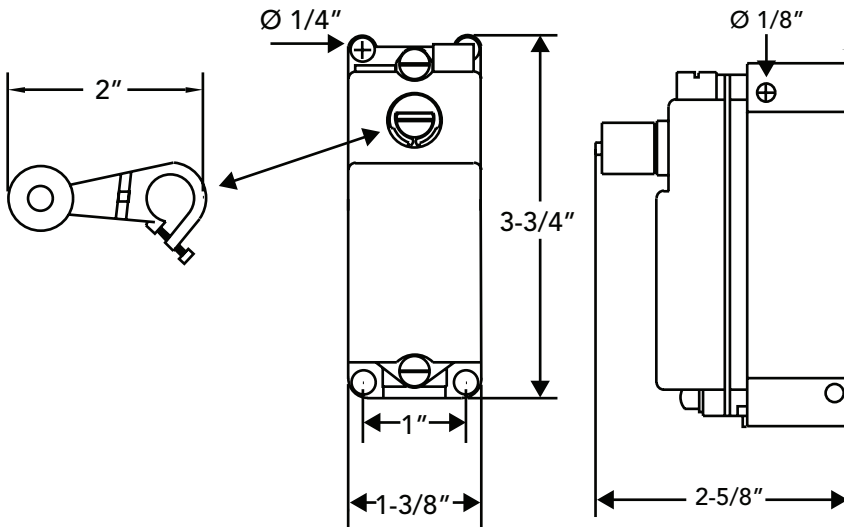

## INTERLOCK SWITCH FOR SECTIONAL DOORS

### Features

- NEMA 4

### Specifications

- Switch rating: 15 A @ 125/250 VAC
- Single pole
- Normally Open or Normally Closed

### Wiring information

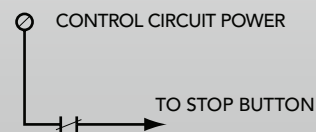

- OR -

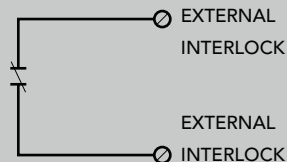

2501 S. State Hwy. 121 Bus., Suite 200, Lewisville, TX 75067  
1-800-929-DOOR • sales@overhaddoor.com  
overhaddoor.com

©2022 Overhead Door Corporation. Overhead Door is a trademark and the Red Ribbon logo is a registered trademark of Overhead Door Corporation. All other trademarks are property of their rightful owners. Consistent with our policy of continuing product improvement, we reserve the right to change product specifications without notice or obligation. C900-1279 02/22



INDUSTRY LEADING  
COMMERCIAL & INDUSTRIAL SOLUTIONS