

The Genuine. The Original.



INSTALLATION INSTRUCTIONS

RAPIDFLEX® MODEL 995LH LOW HEADROOM EXTREME EXTERIOR HIGH SPEED RUBBER DOOR

The Genuine. The Original.



READ THESE
INSTRUCTIONS
THOROUGHLY
BEFORE
ATTEMPTING
TO INSTALL THIS
DOOR!

Product may be covered by
one or more patents.
See www.overheaddoor.com/about-us/patents for
details.

TABLE OF CONTENTS

Section 1 Safety information.....	3-4
Section 2 General information	5-7
Section 3 Door installation	8-12
Section 4 - Low voltage wiring	13-18
Section 5 - High voltage wiring	19-22
Section 6 - Initial startup procedure	23-24
Section 7 - Menus	25-32
Section 8 - Troubleshooting the controller.....	33-38
Section 9 - Service and maintenance	39-40
Section 10 - Warranty	41

SECTION 1 - SAFETY INFORMATION

IMPORTANT SAFETY INSTRUCTIONS

⚠ WARNING

THESE DOORS ARE LARGE, HEAVY OBJECTS THAT MOVE WITH THE HELP OF ELECTRIC MOTORS. SINCE MOVING OBJECTS AND ELECTRIC MOTORS CAN CAUSE INJURIES, YOUR SAFETY AND THE SAFETY OF OTHERS DEPENDS ON YOU READING THE INFORMATION IN THIS MANUAL. IF YOU HAVE ANY QUESTIONS OR DO NOT UNDERSTAND THE INFORMATION PRESENTED, YOU SHOULD CONSULT A LICENSED PROFESSIONAL OR CALL TECHNICAL SUPPORT AT 1-800-764-1457.

DEFINITION OF KEY WORDS USED IN THIS MANUAL:

⚠ DANGER INDICATES A HAZARDOUS SITUATION THAT, IF NOT AVOIDED, WILL RESULT IN DEATH OR SERIOUS INJURY.

⚠ WARNING INDICATES A HAZARDOUS SITUATION THAT, IF NOT AVOIDED, COULD RESULT IN DEATH OR SERIOUS INJURY.



⚠ CAUTION INDICATES A HAZARDOUS SITUATION THAT, IF NOT AVOIDED, COULD RESULT IN MINOR OR MODERATE INJURY.

NOTICE

INDICATES INFORMATION CONSIDERED IMPORTANT, THAT IT IS NOT RELATED TO INJURY, BUT MAY RESULT IN PROPERTY DAMAGE.

IMPORTANT: Required key step for proper door operation.

NOTE: Information only.

Potential Hazard	Effect	Prevention
 MOVING DOOR	⚠ WARNING COULD RESULT IN DEATH OR SERIOUS INJURY	Keep people clear of opening while Door is moving. Do NOT allow children to play with the Door Operator. Do NOT operate a Door that jams or one that has a broken spring.
 ELECTRICAL SHOCK	⚠ WARNING COULD RESULT IN DEATH OR SERIOUS INJURY	Turn OFF electrical power before wiring switch and door operator to supply.
 HIGH SPRING TENSION	⚠ WARNING COULD RESULT IN DEATH OR SERIOUS INJURY	Do NOT try to remove, install, repair or adjust springs or anything to which door spring parts are fastened, such as, wood blocks, steel brackets, cables or other like items. Installations, repairs and adjustments must be done by a trained door system technician using proper tools and instructions.

SECTION 1 - SAFETY INFORMATION (continued.....)

SAFETY INSTRUCTIONS

Electrical Power Requirements for all RapidFlex® Door Models

All RapidFlex® models 991, 992, and 993 are available in single phase and 3-phase voltages. Single phase voltages are available in 115VAC and 240VAC. 3 phase voltages are available in 240VAC, 480VAC, and 575VAC. RapidFlex® model 994 and 995 are available in 3 phase voltages only. **YOUR LOCAL CODES MAY REQUIRE THAT THE INCOMING POWER TO YOUR DOOR HAVE A LOCK-OUT / TAG-OUT EQUIPPED FUSED DISCONNECT SWITCH (TO BE FURNISHED BY OTHERS) WITHIN EYESIGHT OF THE DOOR'S CONTROL PANEL.** Incoming power wiring must meet all NEC and local building codes, plus be properly sized for the control panel's amperage rating on the nameplate. To reduce the risk of electric shock, the chassis of the control panel must be properly grounded.

NOTICE

RAPIDFLEX® DOOR MODELS MUST BE SUPPLIED BY A PROPERLY GROUNDED VOLTAGE SUPPLY, E.G. 220/240 VAC 1-PHASE OR 208/230/460/575 VAC 3-PHASE. FLOATING (OPEN DELTA) UNGROUNDED VOLTAGE SUPPLY SOURCES SHOULD NOT BE USED. FOR 480 VAC, 240 VAC OR 120 VAC UNBALANCED DELTA SYSTEMS SHOULD NOT BE USED. VOLTAGE UNBALANCE IS A COMMON OCCURRENCE ON DELTA SUPPLY SYSTEMS, WHICH POWER BOTH SINGLE PHASE AND THREE PHASE LOADS, WHICH CAN LEAD TO UNEQUAL VOLTAGES ON EACH PHASE LEG. VOLTAGE UNBALANCE CAN CAUSE DETERIORATION OF MOTOR PERFORMANCE, SUCH AS LOSS OF TORQUE, OVERHEATING, DECREASES IN THE WINDING INSULATION LIFE, AND CAN CAUSE MOTOR STARTER CONTACTS ON THE CONTROL PANEL TO PERMANENTLY "WELD" CLOSED. VOLTAGE UNBALANCE CAN BE CAUSED BY INADEQUATE CONDUCTOR SIZING, DELTA TRANSFORMER SIZING, EXCESSIVE SINGLE-PHASE LOADS, POOR GROUNDING, OR INTERMITTENT HIGH RESISTANCE FAULTS WHICH MAY CAUSE DESTRUCTIVE OVER-VOLTAGES TO OCCUR.

OVERHEAD DOOR CORPORATION'S WARRANTY WILL NOT COVER DAMAGE CAUSED BY FAILURE OF THE MOTOR, CONTROL PANEL OR OTHER ELECTRICAL COMPONENTS DUE TO THE USE OF AN INADEQUATELY GROUNDED SYSTEM.

SECTION 2 - GENERAL INFORMATION

COMPONENT IDENTIFICATION DRAWING

Extreme exterior high speed rubber door with parts.

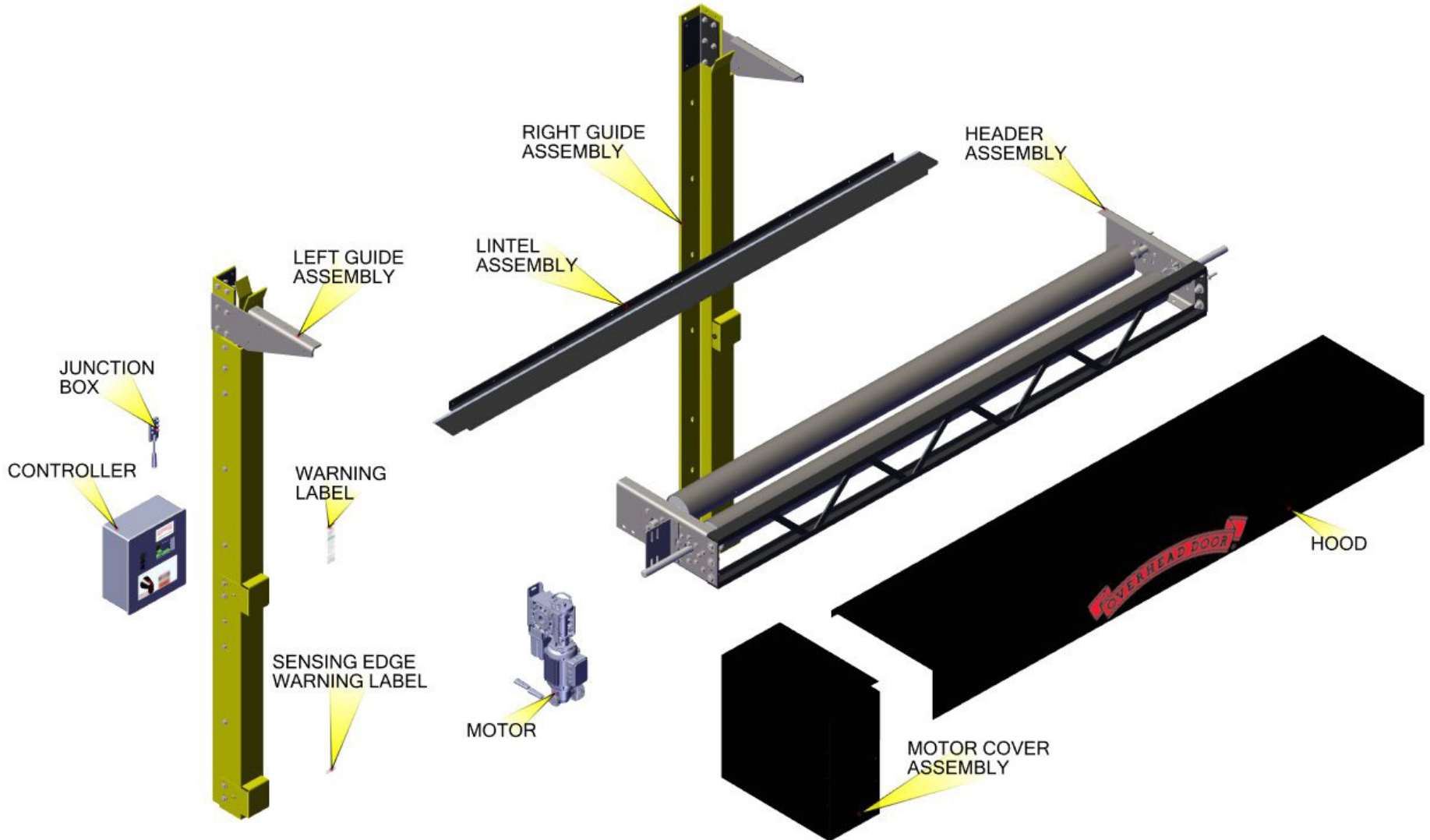

Please note that components and component locations are shown here for REFERENCE ONLY. Your unit installation and component locations may be different.

SECTION 2 - GENERAL INFORMATION (continued.....)

DOOR INSTALLATION SHEET

A sample of the "DOOR INSTALLATION SHEET" is shown here. Locate the work order "Door Installation Data" sheet inside the door hardware box. You will need to refer to the "Door Installation Data" sheet. See **FIG 1**.
 Factory order number on door components must match with factory order number on the "Door Installation Data" sheet. Each door has it's own individual sheet.

Jobless Traveler Report

SO#	SO Line#:	SO Line Item:	
Org Code:	Qty:	Desc:	
Cust. PO:	Customer:	Customer Job:	
Job Name:			
Schl'd Ship Dt:			
Product Desc:			

CURTAIN:
 OPERATION:
 BOTTOM BAR:
 GUIDE:

HOOD/CRATE:

*****	DOOR	INSTALLATION	DATA	*****	*****	*****	*****
MODEL:				S-REFERENCE:			
OPENING WIDTH:		OPENING HEIGHT:		HAND OF OPERATION:		GUIDE TYPE:	
INITIAL TURNS:		RELEASE TURN:		OPERATION TYPE:		CURTAIN/BOTTOM BAR WT:	
TOTAL TURNS:		OPER MOTOR VOLTAGE:		DRIVE NO:		PIPE ASSEMBLY WT:	
GUIDE GAP:		OPER MOTOR TYPE:		GUIDE FINISH:		BRACKET FINISH:	
***** WORK ORDER MESSAGES *****							
**							
**							
**							

FIG 1

SECTION 2 - GENERAL INFORMATION (continued....)

PRE-INSTALLATION CHECK LIST

Verify that the door installation can be accomplished before proceeding:

- Locate the work order "DOOR INSTALLATION DATA" sheet, see **FIG 1**, inside the door hardware box.
- Does the wall opening shown in **FIG 2** match the Opening Width and Height shown on the "Door Installation Data" sheet?
- Can the guides be installed plumb?
- Check the sill for level. If sill is not level, mark the high sill location on the low side jamb.
- Guides are designed to rest on sill.
- Does the "G" dimension on your "DOOR INSTALLATION DATA" sheet match your opening width. See **FIG 3**.

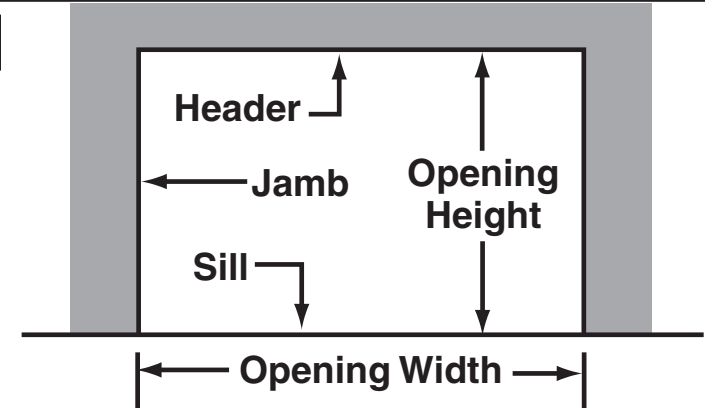

FIG 2

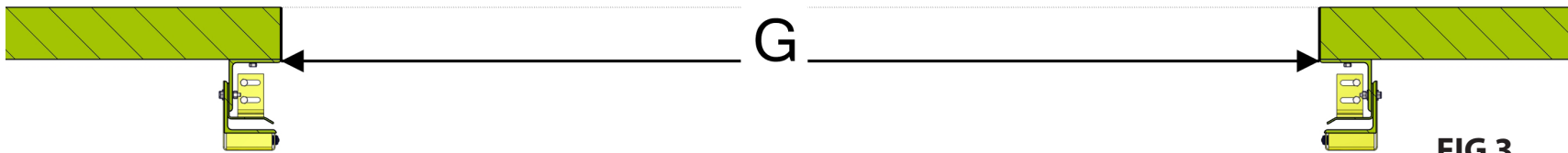

FIG 3

SECTION 3 - DOOR INSTALLATION

⚠ WARNING

FOLLOW INSTRUCTIONS AND USE PROPER LIFTING EQUIPMENT AND CORRECT LIFTING PROCEDURE TO AVOID SERIOUS INJURY OR DEATH.

STEP 1 INSTALL GUIDES

- Check "G" Dimension as illustrated in **FIG 3** on page 7. "G" Dimension must match your "DOOR INSTALLATION DATA" sheet.
- Ideally your "G" dimension will exactly match your opening width. If it does not you must mount your guides so the "G" dimension is held over the entire height.
- Locate the guide assemblies and lay them on the ground in front of the opening.
- Remove pre-installed hardware holding the guide assemblies together and disassemble the guide assemblies. See **FIG 4**.
- Use clamps to mount the wall guides to the wall as shown in **FIG 5**.
- Check "G" Dimension as illustrated in **FIG 3** on page 7. "G" Dimension must match your "DOOR INSTALLATION DATA" sheet.
- Both guides **MUST** be on a level line and both guides **MUST** be plumb.
- The "G" Dimension must be held within 1/8" over the entire height of the guides.
- Install the wall anchors mounting the wall guides to the wall as shown in **FIG 6**.
- Recheck G dimension to be sure it is correct.
- Remove clamps.

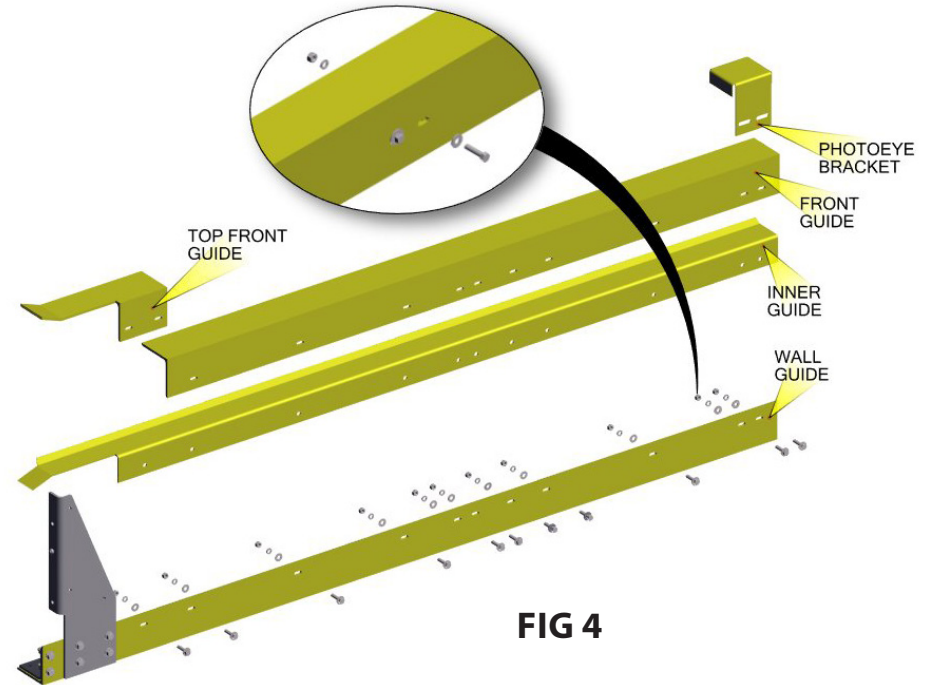

FIG 4

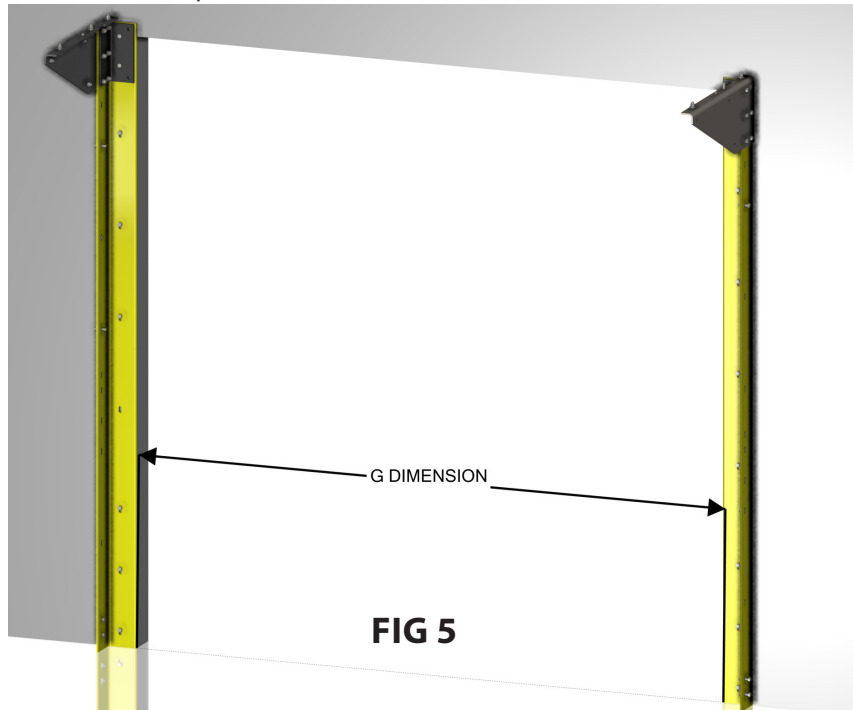

FIG 5

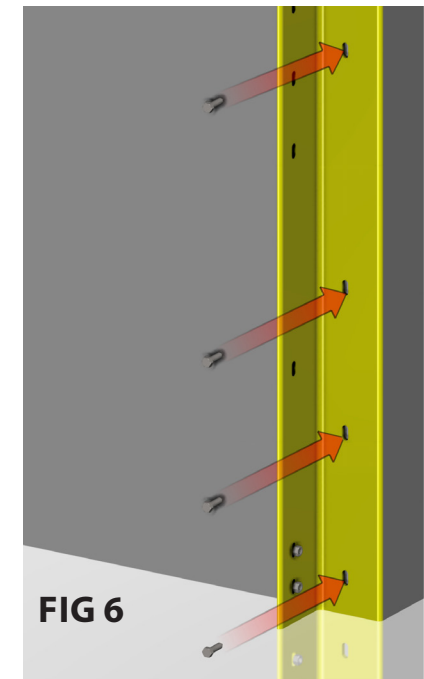

FIG 6

SECTION 3 - DOOR INSTALLATION (continued....)

⚠ WARNING

RAPIDLY CLOSING CURTAIN COULD RESULT IN DEATH OR SERIOUS INJURY. DO NOT REMOVE FACTORY BANDING AROUND CURTAIN ASSEMBLY UNTIL STEP 5.

⚠ WARNING

FOLLOW INSTRUCTIONS AND USE PROPER LIFTING EQUIPMENT AND CORRECT LIFTING PROCEDURE TO AVOID SERIOUS INJURY OR DEATH.

STEP 1 INSTALL GUIDES (CONTINUED...)

- Reassemble the guide assemblies (except the top front guide) in their mounted position on the wall using the hardware you took off earlier in this step. See **FIG 7**.

NOTE: Do not assemble the top front guide yet.

NOTE: Ensure the guide gap is 5/8" the entire height of the guide. Failing to do so may allow the curtain to escape the guide.

- Install concrete anchors through floor plate and into floor on both guides. See **FIG 8**.

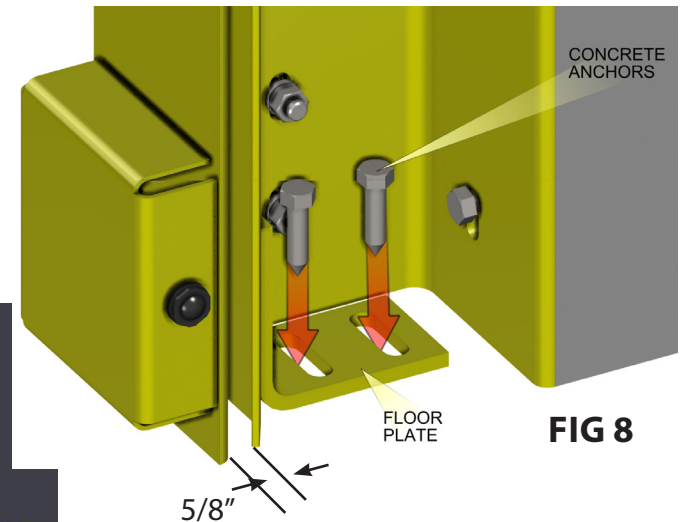

FIG 8

STEP 2 INSTALL LINTEL ASSEMBLY

- Attach the lintel assembly to the lintel as shown in **FIG 9**. Lintel seal should be flush with the bottom of the lintel.

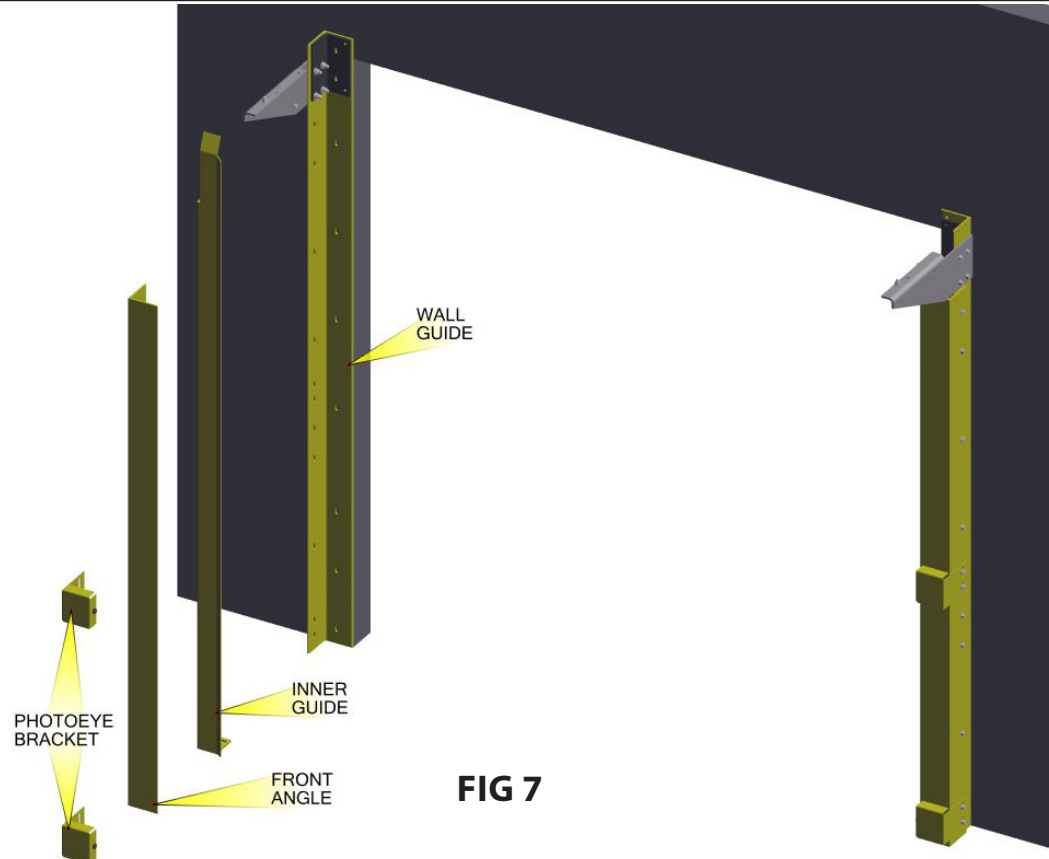

FIG 7

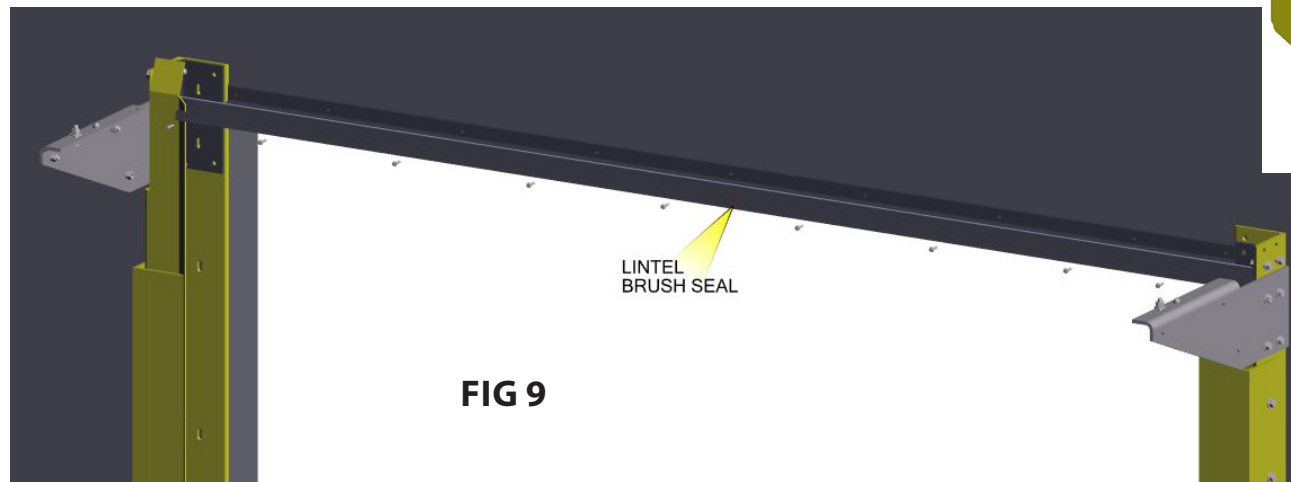

FIG 9

SECTION 3 - DOOR INSTALLATION (continued....)

⚠ WARNING

RAPIDLY CLOSING CURTAIN COULD RESULT IN DEATH OR SERIOUS INJURY. DO NOT REMOVE FACTORY BANDING AROUND CURTAIN ASSEMBLY UNTIL STEP 5.

⚠ WARNING

FOLLOW INSTRUCTIONS AND USE PROPER LIFTING EQUIPMENT AND CORRECT LIFTING PROCEDURE TO AVOID SERIOUS INJURY OR DEATH.

STEP 3 INSTALL HEADER ASSEMBLY

- Remove six sets of pre-installed bolts, washers, and nuts from the top surface of the stage bracket.
- Lift the header assembly using a fork lift or other appropriate lifting equipment and lower it onto the stage brackets as shown in **FIG 10** and **FIG 11**.
- Be sure the stage pins slide into the holes in the headplate. See **FIG 11**. These pins will align and center the header assembly.
- Reinstall the bolts, washers, and nuts to secure the header assembly onto the guides.

STEP 4 INSTALL MOTOR

- Remove pre-installed motor mounting hardware from the mounting bracket, as shown in **FIG 12**. Loosen the mounting bracket hardware so the bracket can slide back and forth as needed. See **FIG 12**.
- Slide motor onto shaft, as shown in **FIG 12**.
- Re-install the motor mounting hardware, securing the motor.
- Re-tighten the mounting bracket hardware.
- Rotate the curtain assembly shaft to align it with the keyway on the motor.
- Insert the key into the keyway. Slide set collar onto shaft and up against the motor. Tighten the set screws in the set collar. See **FIG 13**.

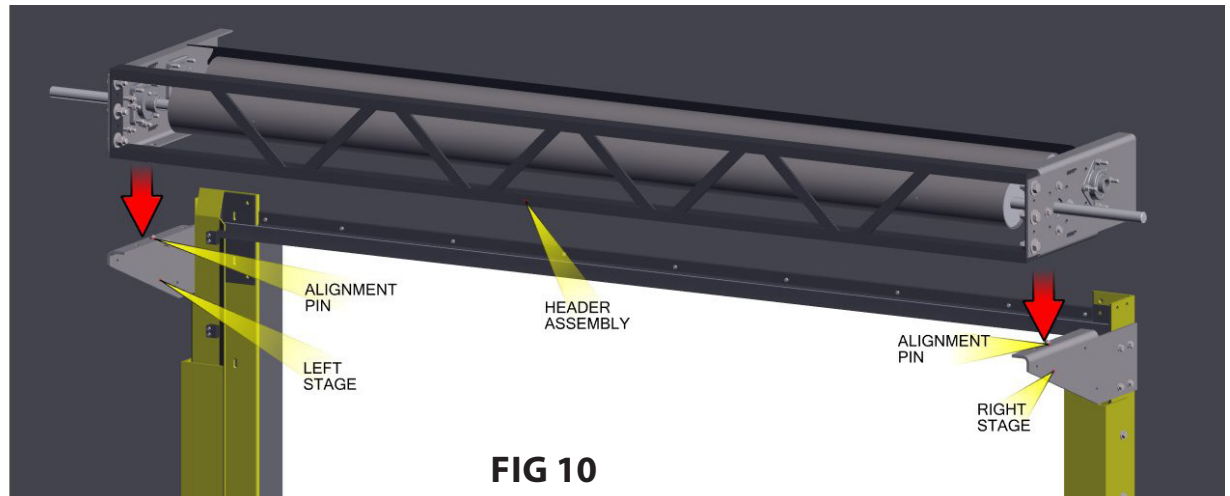

FIG 10

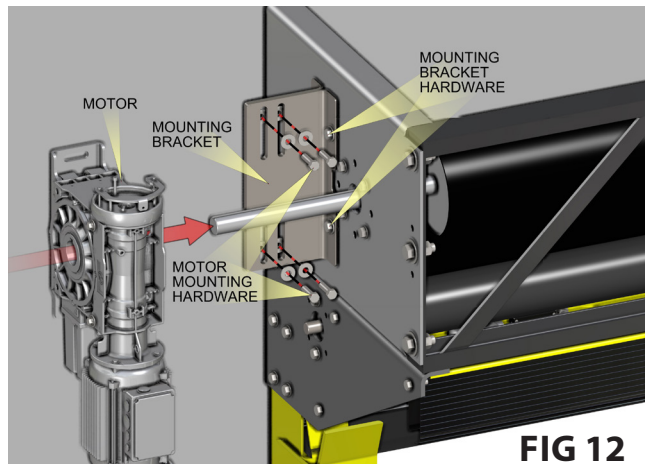

FIG 12

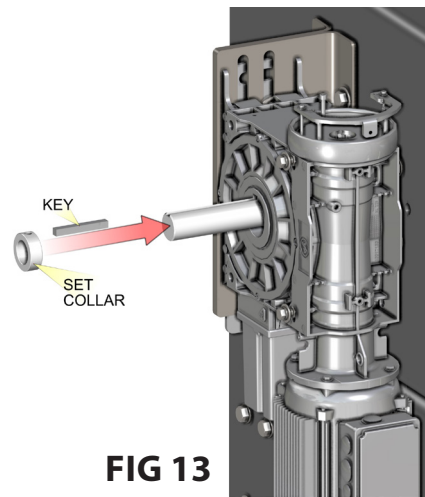

FIG 13

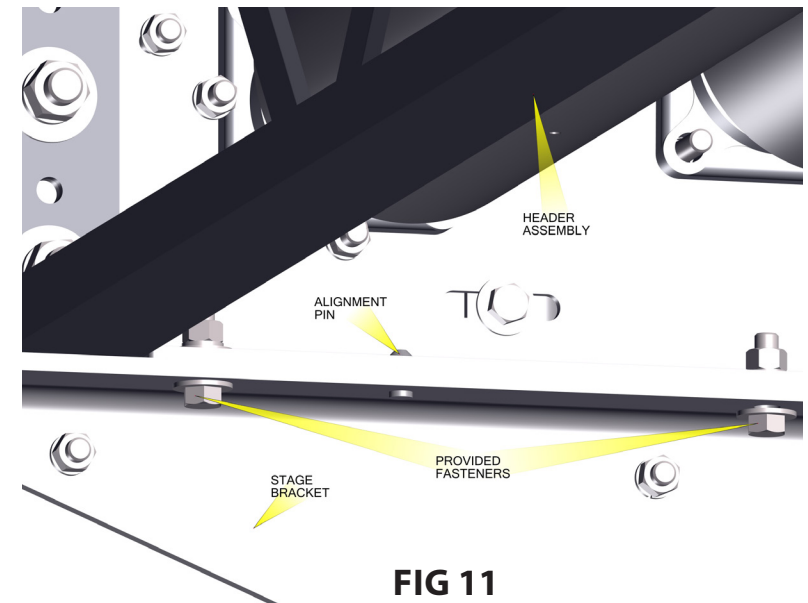

FIG 11

SECTION 3 - DOOR INSTALLATION (continued....)

STEP 6 RELEASE THE CURTAIN ASSEMBLY

- Check to be sure the pre-installed bearings and set collars in the header assembly have not loosened during shipping.
- Remove factory banding around curtain.
- You will need one or more assistant(s) to help lower the curtain for the first time.
- Pull the red handled cord on the motor to activate the chain hoist.
- The assistant(s) will need to push the bottom bar over the idler barrel and down towards the bell mouth while it is being lowered with the hand chain, so it will be routed correctly as shown in **FIG 14**.
- Be sure the curtain assembly passes behind the idler barrel and into the bell mouth and guides as shown in **FIG 14**.
- When the curtain is fully lowered pull the green handled cord to deactivate the chain hoist.
- Now assemble the front guide pieces.

STEP 7 INSTALL JUNCTION BOX

Find a suitable and easily accessible location for the Junction Box. See **FIG 15**.

- Locate the Junction Box on the wall near the motor, but **OUTSIDE** the motor cover. Verify component cables will reach before mounting the Junction Box.
- Away from heat sources.
- With no interference of moving parts of the door system.
- Where cables can be well secured while preventing unnecessary strain.
- Use the Junction Box exterior mounting fixtures to mount to the wall using appropriate fasteners. (Fasteners not provided)

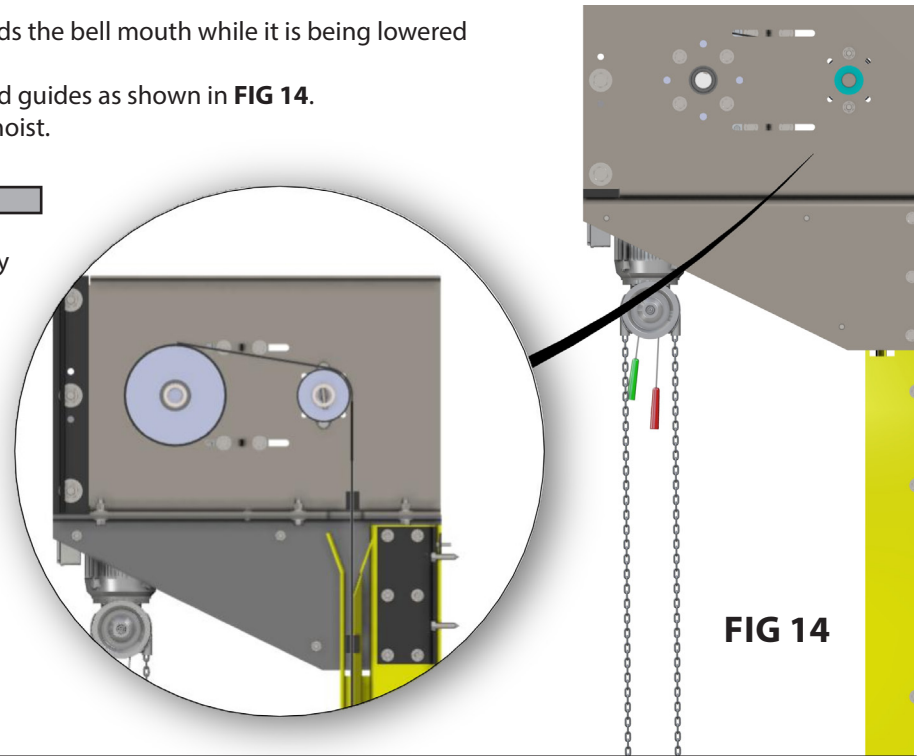
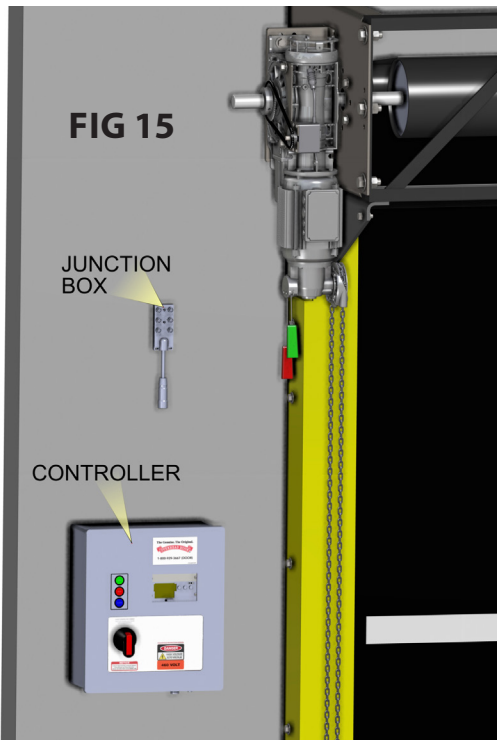

STEP 8 INSTALL CONTROLLER

Find a suitable and easily accessible location for the Controller. See **FIG 15**.

- Adjacent to the door, on the wall, about 5 feet above the floor at the center of the panel (roughly eye level). It may be mounted higher in commercial applications to reduce tampering.
- Where all moving parts of the door system are visible while at the control panel.
- Away from heat sources.
- With no interference of moving parts of the door system.
- Where cables can be well secured while preventing unnecessary strain.
- Mount the Control Panel to the wall using appropriate fasteners. (Fasteners not provided) Use supplied mounting tabs as necessary.

SECTION 3 - DOOR INSTALLATION (continued....)

STEP 8 MOTOR AND CONTROLLER WIRING

- For instructions on wiring the controller see **SECTION 4 AND 5** pages 13-22.

STEP 9 INSTALL HOOD AND MOTOR HOUSING

- Install the hood and motor using the self drilling screws provided.

STEP 10 APPLY WARNING LABEL

Product safety label must be installed.

- Place safety label on drive side guide at a readable height.
- Place sensing edge safety label on the bottom bar.

NOTE: Product safety labels should be periodically inspected and cleaned by the product user as necessary to maintain good legibility. Order replacement safety labels from the door manufacturer as required to maintain legibility.



FIG 16

SECTION 4 - LOW VOLTAGE WIRING

STEP 1 CONNECT CONTROLLER LOW VOLTAGE WIRING (EXTERNAL)

Connections to the door are completed by attaching the two screw-in cables to the control panel's base, **FIG 19** page 15.

-5 pin cable connector (See **FIG 21** and **FIG 22** on page 17)

- Position Sensor

-12 pin cable connector (See **FIG 19** on page 15)

- Photoeye Receiver
- Photoeye Transmitter
- Sensing Edge
- Hand Crank Interlock Switch
- Optional Input 1

STEP 2 INSTALL OPTIONAL DEVICES

INSTALL MOTION SENSOR (optionally purchased)

Motion Sensor is an optional component purchased separately and does **not** come with door.

- Follow the installation instructions accompanying the Motion Sensor.
- Install wiring per wiring diagram **FIG 24** on page 18.

INSTALL LOOP DETECTOR (optionally purchased)

Loop Detector is an optional component purchased separately and does **not** come with door.

- Follow the installation instructions accompanying the Loop Detector.
- Install wiring per wiring diagram **FIG 25** on page 18.

INSTALL RADIO CONTROLS (optionally purchased)

Radio Controls are an optional component purchased separately and does **not** come with door.

- Follow the installation instructions accompanying the Radio Controls.
- Install wiring per wiring diagram **FIG 23** on page 18.

INSTALL WALL MOUNTED PUSH BUTTON (optionally purchased)

Wall Mounted Push Buttons are an optional component purchased separately and does **not** come with door.

- Install wiring per wiring diagram **FIG 34** on page 35.

STEP 3 CONNECT OPTIONAL DEVICES

Two options may be connected to the Junction Box by the installer. Additional options must be wired to the spare inputs on the Control panel. Use the corresponding option inputs.

- Radio Remote to the Junction Box connector 6 labeled "Option 2".
- Floor loop to the Junction Box connector 5 labeled "Option 1".
- Motion Detector to the Junction Box connector 5 labeled "Option 1".
- Wall mounted push button stations to the main Control Panel **FIG 34** on page 35.

NOTE: When installing push buttons, use the 24V supplied by the Control Unit as the common.

SECTION 4 - LOW VOLTAGE WIRING (continued....)

1. MAIN COMPONENT OVERVIEW, FIG 17 AND 18

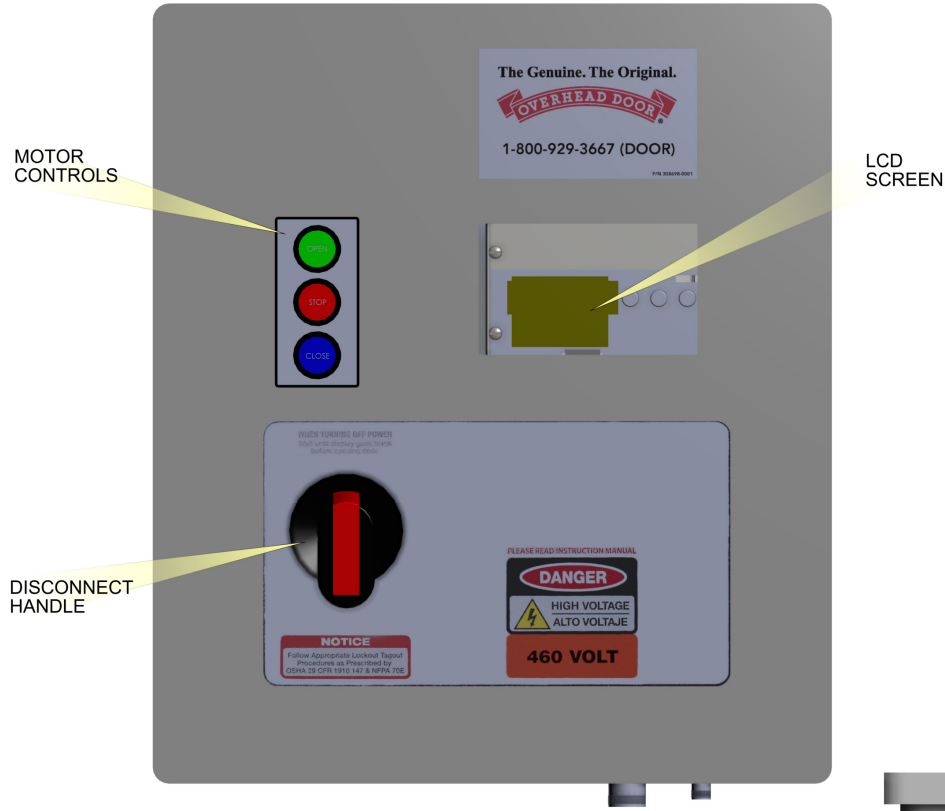

FIG 17 Control Panel Front Cover

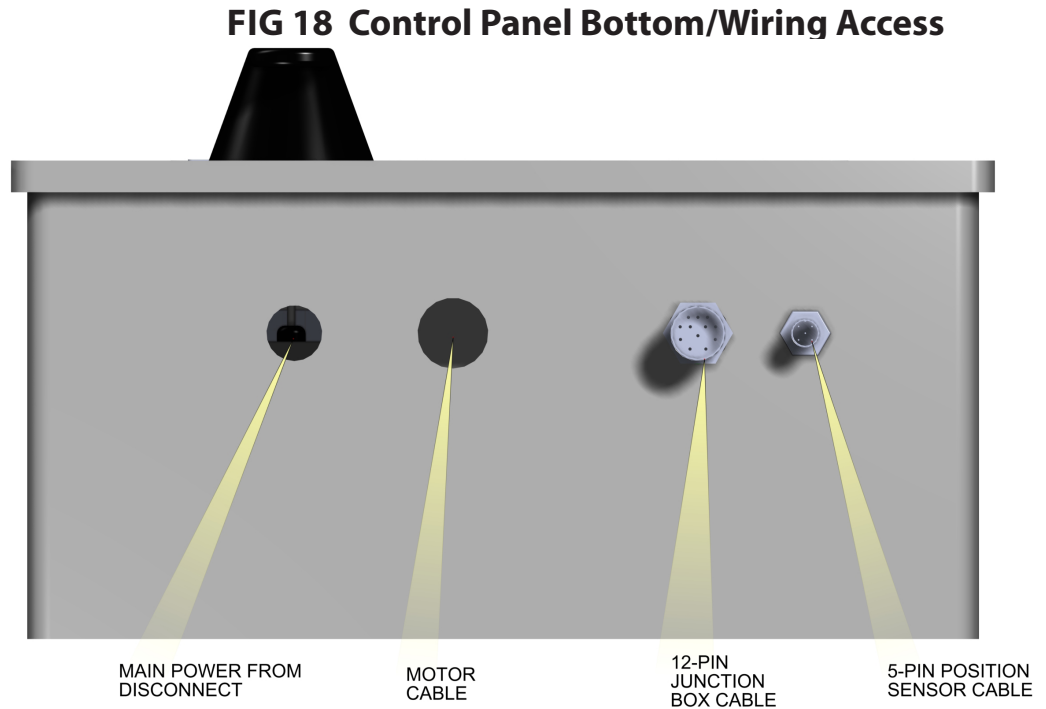

FIG 18 Control Panel Bottom/Wiring Access

SECTION 4 - LOW VOLTAGE WIRING (continued....)

TO JUNCTION BOX

1. SENSING EDGE (WHITE)
2. INTERLOCK (GREEN)
3. NOT USED
4. PHOTOEYE RECEIVER (GRAY)
5. OPTION 1 (PINK)
6. OPTION 2 (RED)
7. NOT USED
8. NOT USED
9. NOT USED
10. COMMON (0V) (BLUE)
11. POWER (24V) (BROWN)
12. GND (GREEN/YELLOW)

TO ENCODER

1. 12V (BROWN)
2. A SIGNAL (WHITE)
3. B SIGNAL (BLUE)
4. 0V (BLACK)
5. PULSE (GRAY)

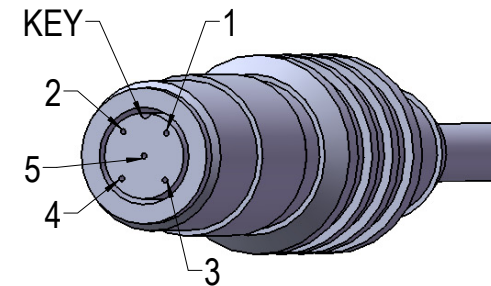
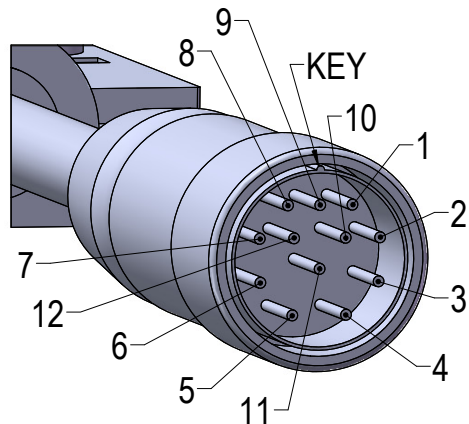
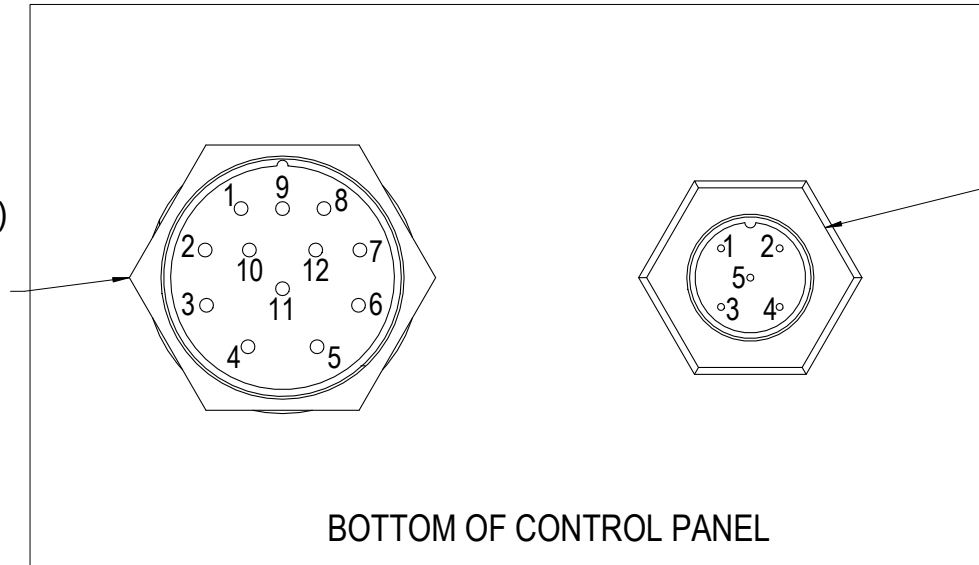

FIG 19 Cables to Control Panel

SECTION 4 - LOW VOLTAGE WIRING (continued....)

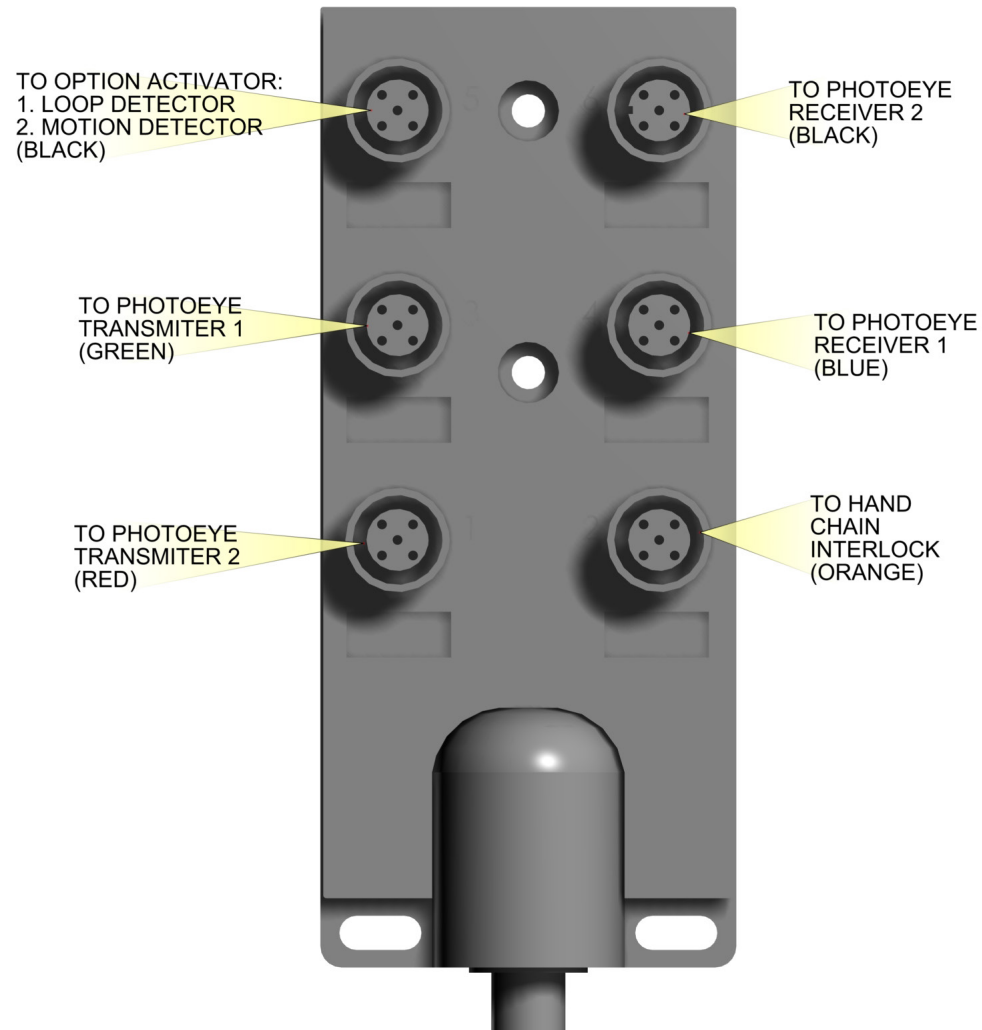

FIG 20 JUNCTION BOX WIRING
Connections for most factory wired external control functions.

SECTION 4 - LOW VOLTAGE WIRING (continued....)

4. POSITION SENSOR WIRING CONNECTIONS AND SETTINGS

The Position Sensor comes pre installed to the motor. See **FIG 21** for location.

- Attach one end of the M12 position sensor cable to the Position Sensor.
- Attach the other end of the M12 position sensor cable to the Control Panel.

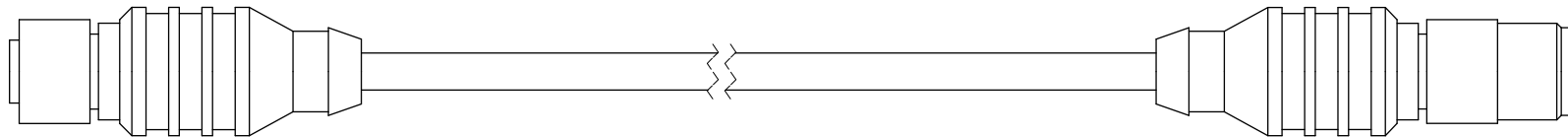
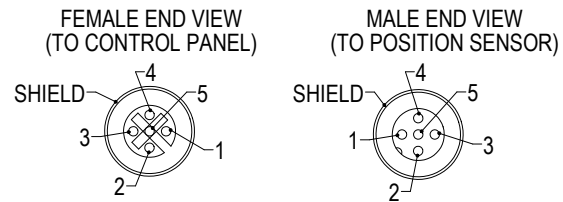
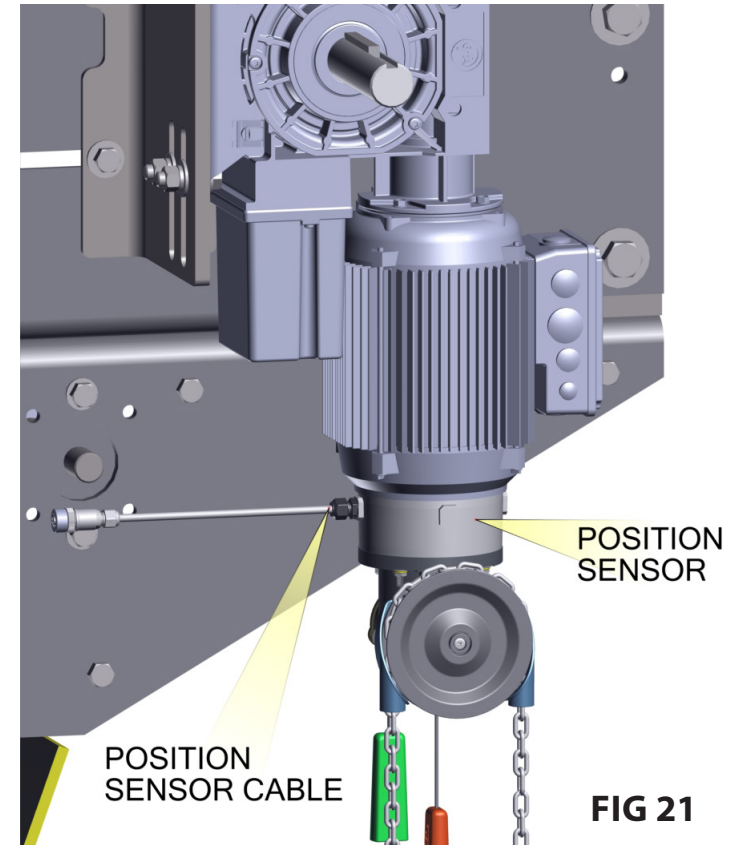
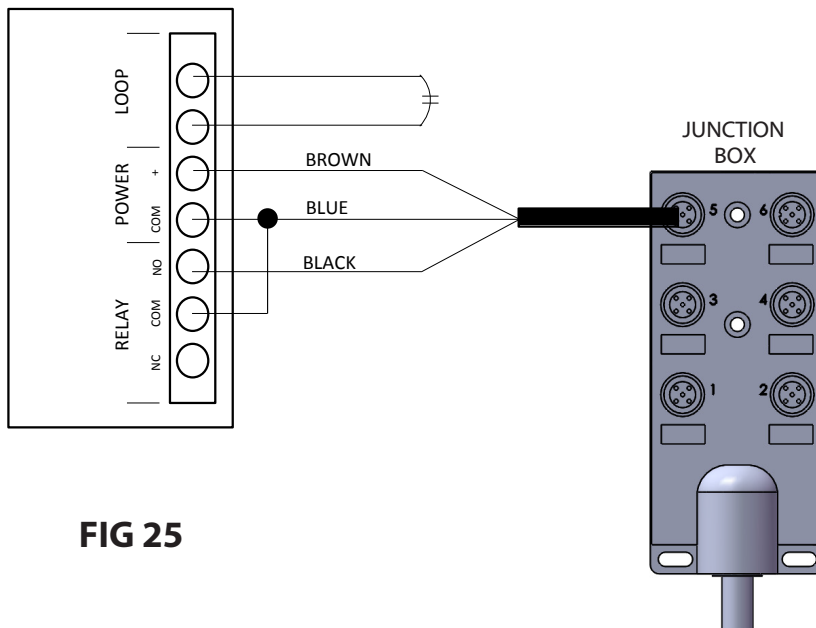
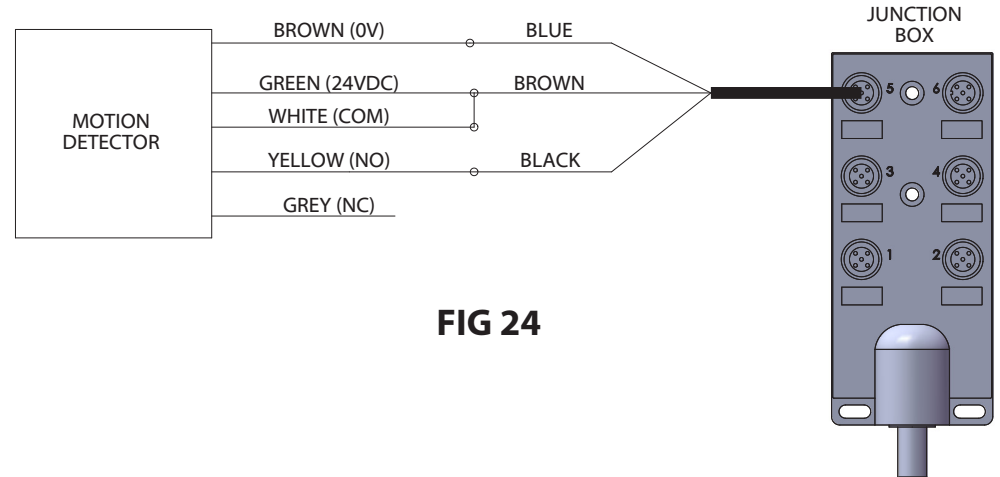
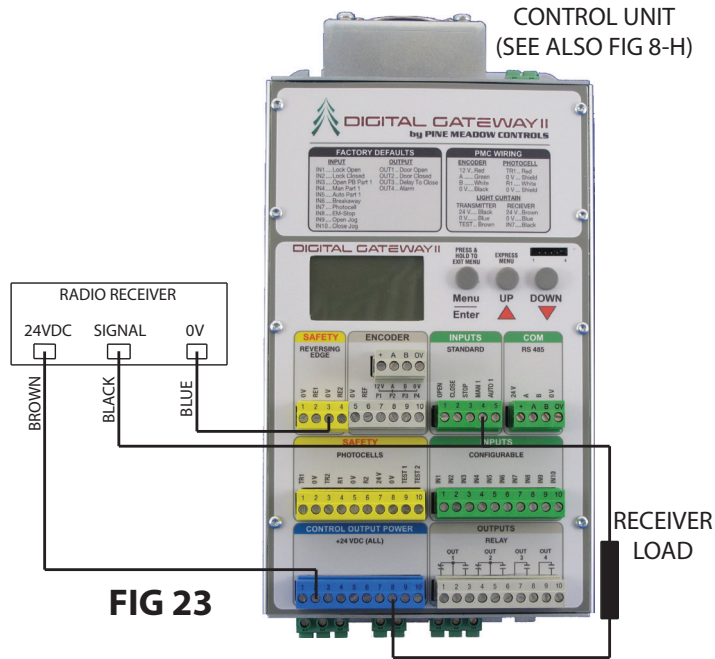

FIG 22 POSITION SENSOR CABLE

SECTION 4 - LOW VOLTAGE WIRING (continued....)



5. OPTIONS WIRING AND SETTINGS

- Wire the supplied cables from the junction box to the optional equipment as shown in **FIG 24**, and **FIG 25**.
- Wire the Radio receiver directly into the controller (through an available opening) as shown in **FIG 23**.

CAUTION

DOOR WILL OPEN/CLOSE ONCE CONNECTED.

- A. For the radio receiver, wire the supplied receiver load into the control unit from MAN1 to 24VDC (blue terminal).
1. Access the menu and navigate to system config-> Inputs-> MAN1-> Logic.
 2. Select NC parameter and exit the menu.
 3. To update the auto close timer, access the express menu->MAN1 Timer
- B. The motion detector and loop detector can be operational once connected to the junction box. They are wired for the default configuration.
1. To update the auto close timer, access the express menu->AUTO1 Timer.

SECTION 5 - HIGH VOLTAGE WIRING

⚠ WARNING

BEFORE BEGINNING THIS PHASE OF THE INSTALLATION, ENSURE POWER SUPPLY IS DISCONNECTED TO AVOID SERIOUS INJURY OR DEATH!

NOTICE

RAPIDFLEX® DOOR MODELS MUST BE SUPPLIED BY A PROPERLY GROUNDED VOLTAGE SUPPLY, E.G. 220/240 VAC 1-PHASE OR 208/230/460/575 VAC 3-PHASE. FLOATING (OPEN DELTA) UNGROUNDED VOLTAGE SUPPLY SOURCES SHOULD NOT BE USED. FOR 480 VAC, 240 VAC OR 120 VAC UNBALANCED DELTA SYSTEMS SHOULD NOT BE USED. VOLTAGE UNBALANCE IS A COMMON OCCURRENCE ON DELTA SUPPLY SYSTEMS, WHICH POWER BOTH SINGLE AND 3-PHASE LOAD. THIS CAN LEAD TO UNEQUAL VOLTAGES ON EACH PHASE LEG. VOLTAGE UNBALANCE CAN CAUSE DETERIORATION OF MOTOR PERFORMANCE SUCH AS LOSS OF TORQUE, OVERHEATING, DECREASES IN THE WINDING INSULATION LIFE, AND CAN CAUSE MOTOR STARTER CONTACTS ON THE CONTROL PANEL TO PERMANENTLY "WELD" CLOSED. VOLTAGE UNBALANCE CAN BE CAUSED BY INADEQUATE CONDUCTOR SIZING, DELTA TRANSFORMER SIZING, EXCESSIVE SINGLE PHASE LOADS, POOR GROUNDING OR INTERMITTENT HIGH RESISTANCE FAULTS WHICH MAY CAUSE DESTRUCTIVE OVER-VOLTAGES TO OCCUR. IF A 240 VAC 3-PHASE DELTA SYSTEM MUST BE USED, IT IS STRONGLY RECOMMENDED THAT THIS VOLTAGE BE TRANSFORMED TO A 220/240 VAC 1-PHASE GROUNDED WYE SYSTEM. ANY SINGLE PHASE LOADS SHOULD BE EVENLY DISTRIBUTED AS MUCH AS POSSIBLE BETWEEN THE 3 PHASES. CONSULT A LICENSED ELECTRICIAN IF YOU HAVE ANY QUESTIONS.

OVERHEAD DOOR CORPORATION'S WARRANTY WILL NOT COVER DAMAGE CAUSED BY FAILURE OF THE MOTOR, CONTROL PANEL OR OTHER ELECTRICAL COMPONENTS DUE TO THE USE OF AN INADEQUATELY GROUNDED SYSTEM.

ALL RAPIDFLEX® MODELS 991, 992, AND 993 ARE AVAILABLE IN SINGLE PHASE AND 3-PHASE VOLTAGES. SINGLE PHASE VOLTAGES ARE AVAILABLE IN 115VAC AND 240VAC. 3 PHASE VOLTAGES ARE AVAILABLE IN 240VAC, 480VAC, AND 575VAC. RAPIDFLEX® MODEL 994 AND 995 ARE AVAILABLE IN 3 PHASE VOLTAGES ONLY. YOUR LOCAL CODES MAY REQUIRE THAT THE INCOMING POWER TO YOUR DOOR HAVE A LOCK-OUT / TAG-OUT EQUIPPED FUSED DISCONNECT SWITCH (TO BE FURNISHED BY OTHERS) WITHIN EYESIGHT OF THE DOOR'S CONTROL PANEL. INCOMING POWER WIRING MUST MEET ALL NEC AND LOCAL BUILDING CODES, PLUS BE PROPERLY SIZED FOR THE CONTROL PANEL'S AMPERAGE RATING ON THE NAMEPLATE. TO REDUCE THE RISK OF ELECTRIC SHOCK, THE CHASSIS OF THE CONTROL PANEL MUST BE PROPERLY GROUNDED.

⚠ WARNING

TO AVOID SERIOUS INJURY OR DEATH:

- IT IS RECOMMENDED THAT LINE VOLTAGE WIRING BE PERFORMED BY A QUALIFIED ELECTRICIAN.**
- BE SURE THAT ELECTRICAL POWER HAS BEEN DISCONNECTED FROM THE INPUT WIRES BEING CONNECTED TO THE OPERATOR PRIOR TO HANDLING THESE WIRES. AN APPROPRIATE LOCK-OUT/TAG-OUT PROCEDURE IS RECOMMENDED.**
- LINE VOLTAGE MUST MEET ALL LOCAL BUILDING CODES.**
- MAKE SURE OPERATOR VOLTAGE, PHASE, AND FREQUENCY RATINGS ARE IDENTICAL TO THE JOB SITE LINE VOLTAGE RATINGS.**
- INPUT POWER WIRING MUST BE PROPERLY SIZED FOR THE OPERATORS AMPERAGE RATING.**

⚠ WARNING

TO AVOID SERIOUS INJURY OR DEATH DO NOT CALIBRATE MOTOR OR OPERATE DOOR UNLESS DOORWAY IS IN SIGHT AND FREE OF OBSTRUCTIONS. KEEP CLEAR OF OPENING WHILE DOOR IS MOVING.

SECTION 5 - HIGH VOLTAGE WIRING (continued....)

⚠ DANGER

BEFORE BEGINNING THIS PHASE OF INSTALLATION, ENSURE POWER SUPPLY IS DISCONNECTED TO AVOID SERIOUS INJURY OR DEATH!

MOTOR & POWER WIRING (HIGH VOLTAGE) (These tasks are also diagrammed in **FIG 26, 27, and 28** on pages 20-22.)

- A.** Route **Motor Power Cable** (provided, factory wired to motor) through water-tight fitting in the **SECOND** hole from left side of Control Panel bottom.
1. Connect the lighter gauge, twisted pair wires to the blue colored **Motor Brake** terminals next to the disconnect switch. Either wire can connect to either terminal. It is labeled "B1" and "B2".
 2. Connect the green and yellow ground wire, the braided cable shield and the non-insulated ground wire together to the Green and Yellow terminal.
 3. Connect the thicker motor wires to Terminals T1, T2 and T3 on the green screw connectors on the bottom left of the control unit. The order doesn't matter since the motor rotation can be changed using the internal programming during Set-up in **SECTION 6**.

A licensed electrician must perform the following step.

- B.** Route **Main Power Cable** (not provided) through a water-tight fitting (not provided) in the **FIRST** hole from the left side of the Control Panel bottom.
- Connect 3-phase power lines to the disconnect. Connect the ground wire to the Ground Terminal to the left of the disconnect.

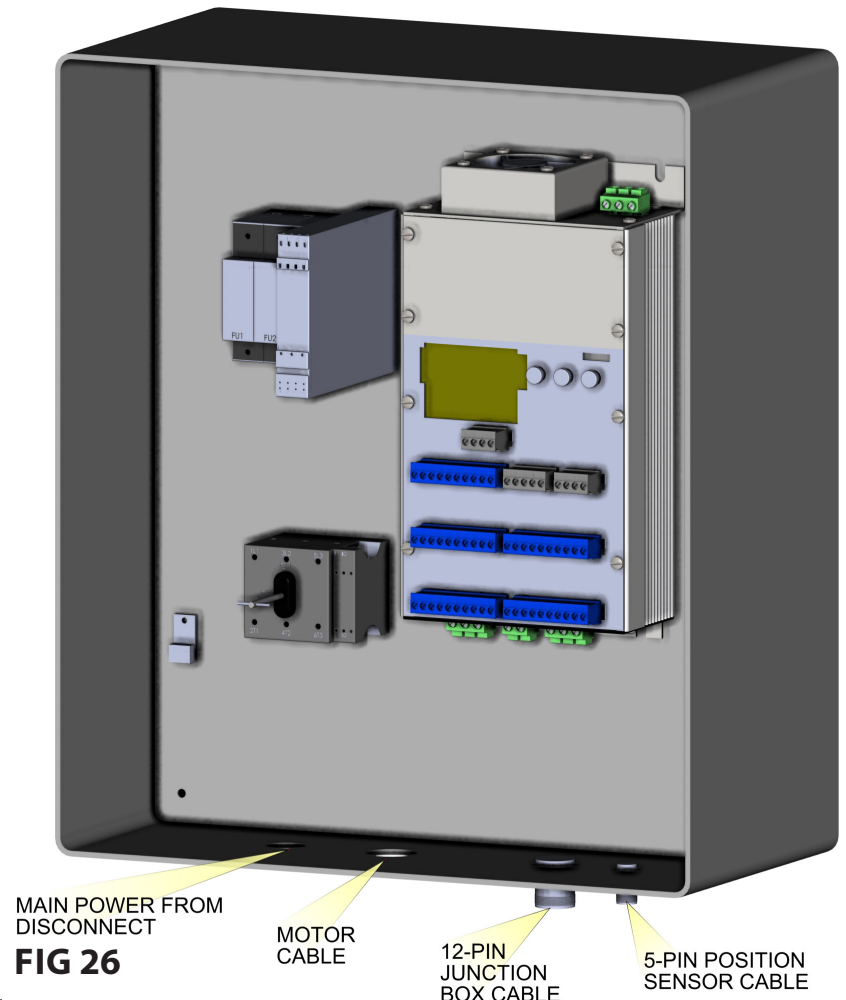
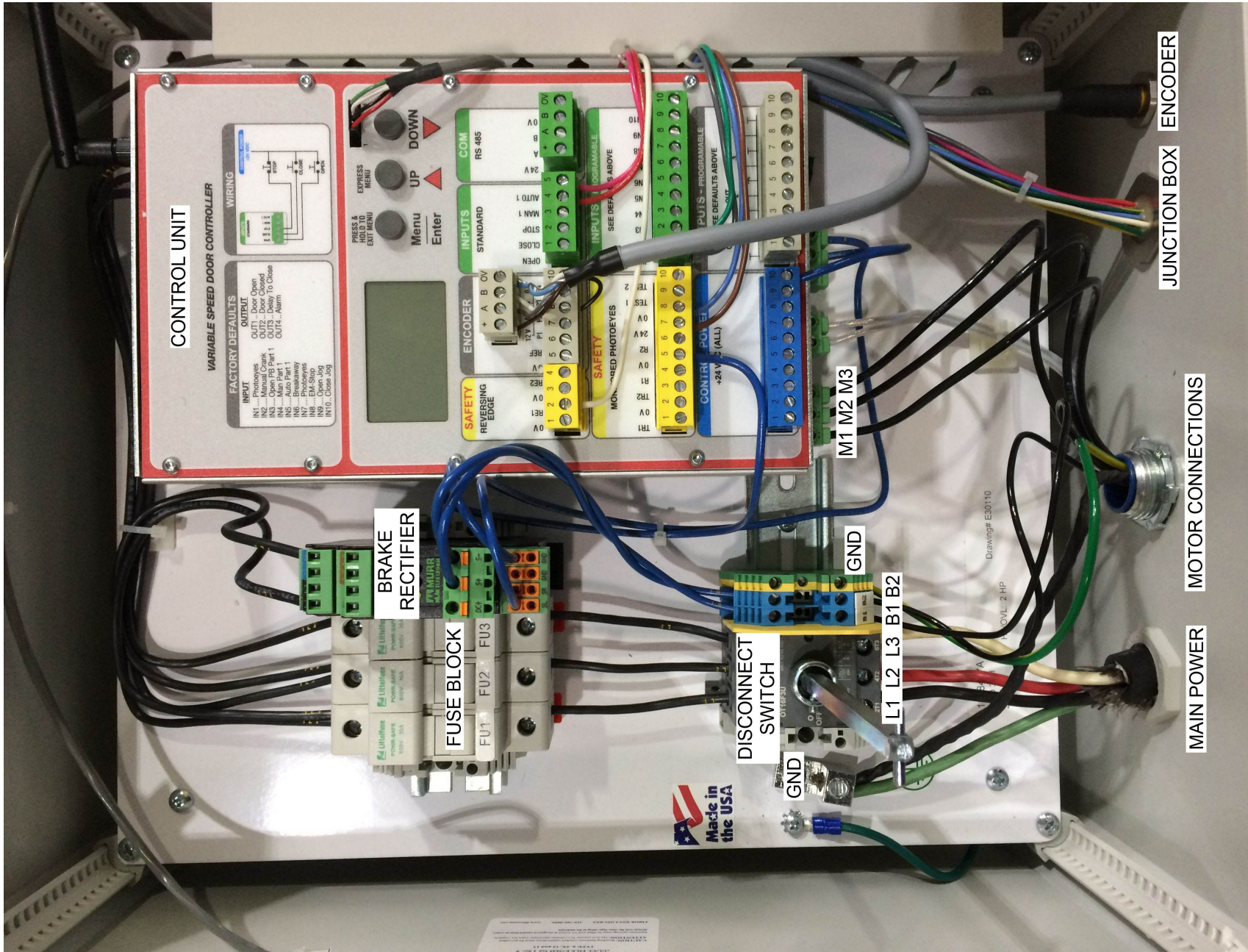

FIG 26

SECTION 5 - HIGH VOLTAGE WIRING (continued....)

FIG 27 Control Panel Contents (See also FIG 33)



SECTION 5 - HIGH VOLTAGE WIRING (continued....)

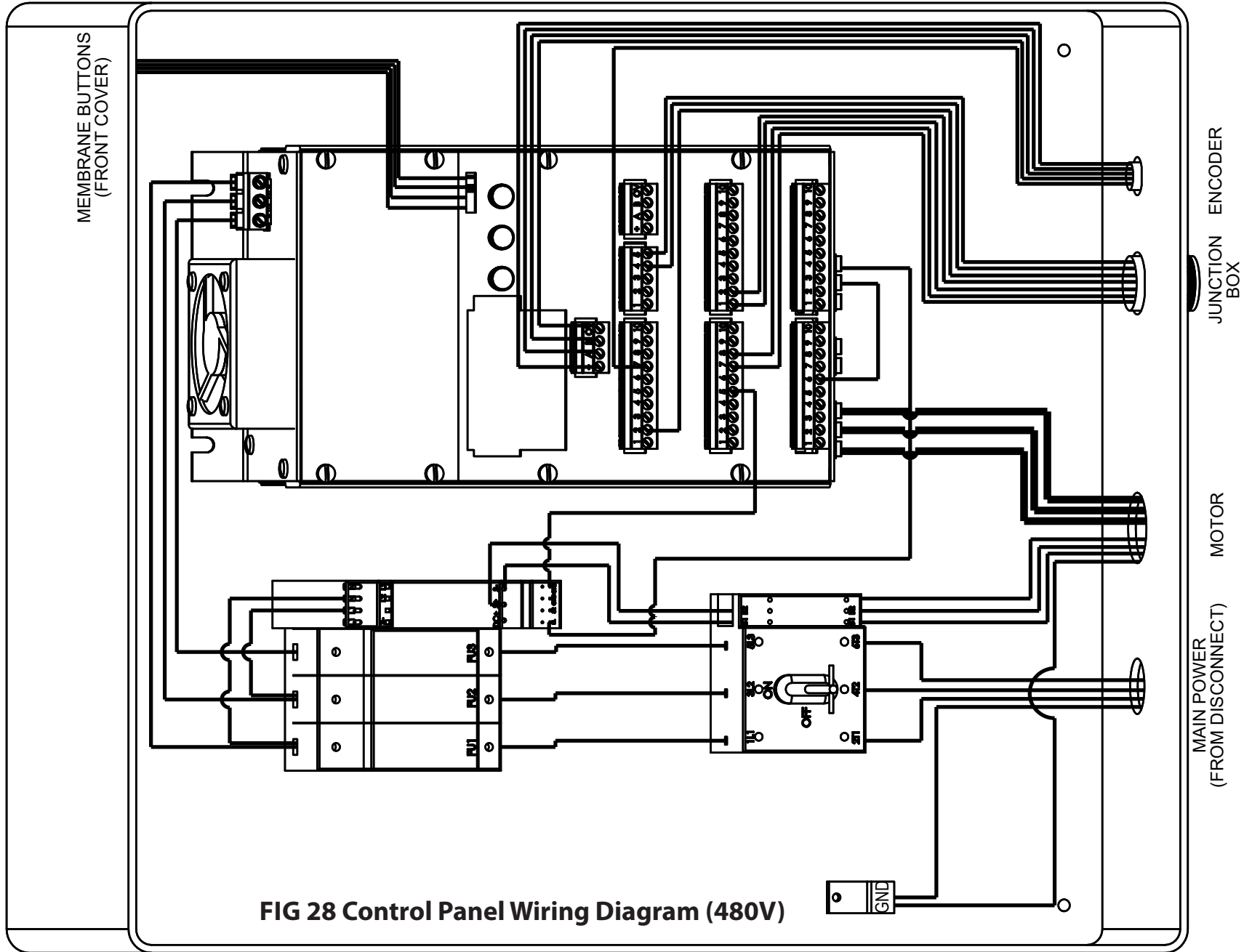

FIG 28 Control Panel Wiring Diagram (480V)

SECTION 6 - INITIAL STARTUP PROCEDURE

STEP 1 APPLY POWER (LINE VOLTAGE)

Turn the disconnect handle Clockwise to the ON position in order to apply power to the Control Panel. A blue splash screen will pop up displaying the default profile, and controller data (consists of serial number, output capacity, software version, etc). Verify the system motor rating, and power ratings correspond with each other.

NOTE*: The system information can also be accessed in the SYSTEM STATUS > OVERVIEW menu. (see page 35-37)

STEP 2 INITIAL LIMIT SETUP

The first time the controller is powered on, you must first set the limits. The LED screen will flash with the error E17, and you must reset the limits. This will also occur whenever the position sensor is disconnected from the controller. The position sensor, photoeyes, sensing edge, and interlock switch must be connected before the limits can be set. If, for any reason, the limits cannot be set, please refer to troubleshooting **SECTION 8**.

A. To enter the Menu, press and hold the OPEN, STOP, CLOSE membrane buttons for 3 seconds. A count down timer on the top left corner of the LED screen will display the remaining time left to hold. Refer to **FIG 29** on page 25 for the complete menu structure.

B. Holding the Stop button for 1 second will go back up a level in the Menu. Continuing to hold the STOP button will continue to go back up the menu structure until the main screen.

C. Once in the main screen, a 25 second countdown timer will show on the upper left hand corner. This countdown timer displays how long until the OPEN/STOP/CLOSE buttons will no longer give access to the MENU. Once inside the menu, use the **OPEN button to scroll up**, **STOP button to enter**, and **CLOSE to scroll down**. Pressing OPEN/STOP/CLOSE immediately exits the counter.

NOTE: Instead of using the front panel buttons one can access the menu from the control unit using menu/enter, the ▲, and ▼ buttons.

1. Enter the Menus
2. Scroll down until you reach the LIMIT SETUP and hit enter.
3. Scroll down and enter into Quick Setup. A code request screen will appear. Enter the 3 digit pass code to gain access by scrolling up or down. Your pass code is located on a separate addendum.

NOTE: Do not display or freely give out the pass code

4. Follow the prompts in order to set the open and close limits on the door. During this time, use the OPEN, CLOSE buttons to move the door. Again, the STOP button will be used as the ENTER function. If no error has occurred, it will then display QUICK SETUP DONE, otherwise if failed; QUICK SETUP ABORTED and it must be redone. Refer to Trouble shooting **SECTION 8** if required.

NOTE: Even if the door moves in the opposite direction, proceed with the steps in order. You will have the option to reverse polarity later.

NOTE: When setting the position, the position sensor count will be displayed. Verify the encoder count increases when the door is moving in the up direction, and does not roll over to the negative position.

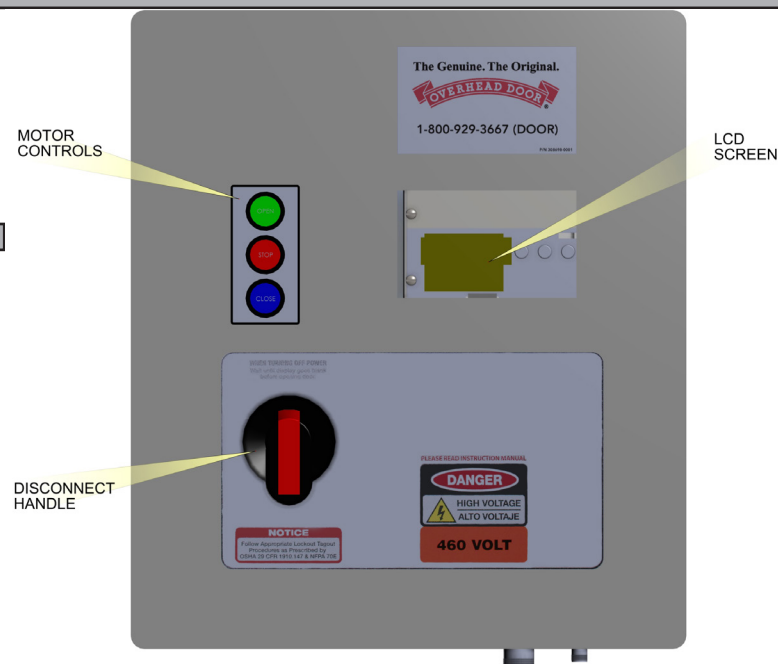

SECTION 6 - INITIAL STARTUP PROCEDURE (continued....)

⚠ WARNING

ALL ENTRAPMENT PROTECTION DEVICES ARE OFF IN EMERGENCY JOG AND THE LIMITS ARE NOT SET. DEVICES OFF WHILE IN EMERGENCY JOG INCLUDE: EDGE CONTACT, PHOTOEYE, WALL PUSH BUTTONS, RADIO CONTROL, LIMIT SENSORS, LOOP DETECTOR, OR ANY MOTION SENSOR USED AS EITHER AN ACTUATOR OR AN ENTRAPMENT PROTECTION DEVICE. ONLY THE INTERLOCK REMAINS ACTIVE.

EMERGENCY JOG IS THE MANUAL CONTROL FOR MOMENTARY OPERATION OF DOOR VIA ARROW BUTTONS ON THE MEMBRANE KEYPAD OR ON THE CONTROL UNIT.

USE CAUTION WHILE SETTING UP THE DOOR IN THIS MODE, AND KEEP OPENINGS CLEAR OF PERSONS AND PROPERTY TO AVOID SERIOUS INJURY OR DEATH! DO NOT USE EMERGENCY JOG FOR GENERAL DOOR OPERATION.

STEP 3 PAIR THE WIRELESS SENSING EDGE HOST (SEYWAVE HOST)

The wireless sensing edge host must be paired with the controller.

- A. Enter the Menu
- B. Scroll down until you reach the SYSTEM CONFIG and hit enter.
- C. Scroll down and enter into OPTIONS. A code request screen will appear. Enter the 3 digit passcode to gain access by scrolling up or down. Your pass code is located on a separate addendum.
- D. Select SeyWave Host
- E. Select enable and make sure the black box is positioned on enable. If not, select enable and press menu/enter once. The black box will move to enable. Press and hold the menu/enter for a second to back out 1 screen.
- F. Select clear all and press up to confirm.
- G. Select pair and press the sensing edge. The controller will make a beeping noise when the pairing is complete.
- H. Press and hold the menu/enter to go back to the home screen.

STEP 4 VERIFICATION

Test each sensor to make sure the controller recognizes the fault.

- A. Photoeyes -Obstruct the beam with a sold object. Photoeye should reverse door direction.
- B. Sensing Edge -Place a solid object, taller than 12", on the floor and close the door. Sensing edge should reverse door direction on contact with object.
- C. Interlock Switch -This is a constant activation sensor, release the hand chain from the switch, the door should stop and a fault display.

NOTE: All faults and sensor activations are logged into the Fault Log. Access this through the menu SYSTEM STATUS > FAULT LOG in the Controller Menu. To clear faults hold the STOP button for 1 second once the fault has been fixed.

STEP 5 SET SENSING EDGE SENSITIVITY

If you are in a high wind area you may need to adjust the sensitivity of the safety edge so that it does not trigger due to a high wind event.

- A. Enter the Menu
- B. Scroll down until you reach the SYSTEM CONFIG and hit enter.
- C. Scroll down and enter Options. Then select Seawave host pairing. Then select impact adjust and preset.
- D. Now make your sensitivity selection low, medium, or high.

SECTION 7 - MENUS

PART 1 EXPRESS MENU

The Express Menu is accessed by scrolling up, when at the idle screen or after exiting the menus. The express menu contains display options, timers, settings reset, and the emergency JOG. The timer functions in the Express Menu are shortcuts to timers in the system configuration menu without the need of a pass code.

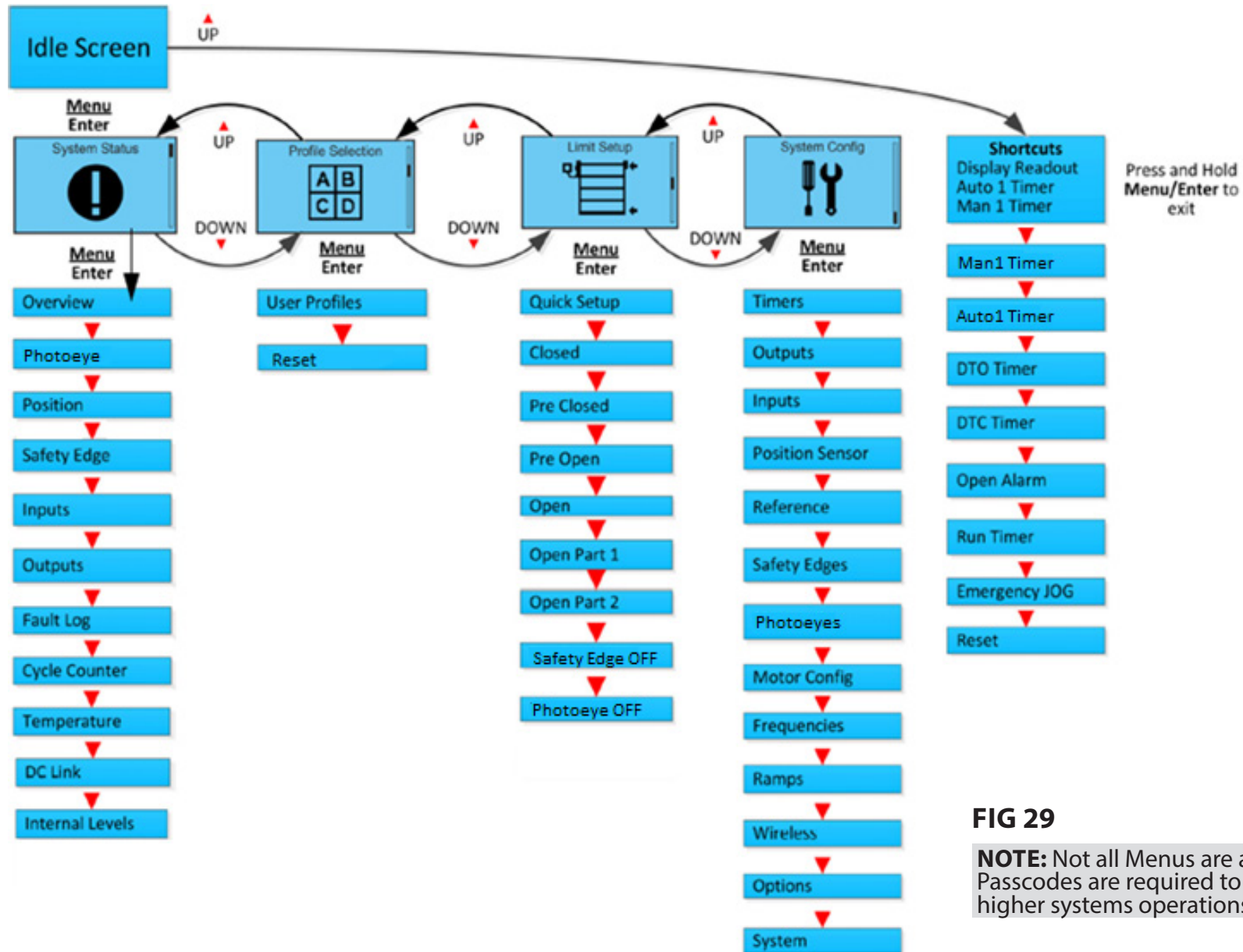

FIG 29

NOTE: Not all Menus are accessible. Passcodes are required to access higher systems operations.

SECTION 7 - MENUS (continued.....)

PART 2 SYSTEM STATUS MENU (continued.....)



Cycle counter shows the number of operating cycles the door has completed (open/close = 1 cycle). Note: This is already shown by default at the top left corner in the main screen.

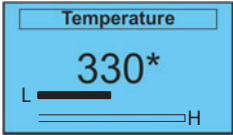

Temperature shows the internal temperature of the DGII Controller. This is a raw analog value and does not represent degrees centigrade or Fahrenheit. A display on the bottom graphically approximates either a Low or High temperature

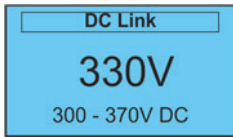

DC Link shows the internal DC Link voltage along with the acceptable range.

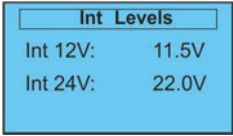

INT Levels shows the control's actual internal supply voltages.

SECTION 7 - MENUS (continued.....)

NOTICE

TO AVOID POTENTIAL EQUIPMENT DAMAGE DO NOT CHANGE THE CONTROLLERS PROFILE UNLESS ADVISED TO DO SO BY YOUR PLANT SERVICE TECHNICIAN. THERE ARE MULTIPLE 995 PROFILES. YOU WILL NEED THE CORRECT ONE BASED ON YOUR PARTICULAR DOOR AND MOTOR CONFIGURATION.

PART 3 PROFILE SELECTION MENU

The profile selection is done at the factory by default. Profiles can be selected based on the door the controller is operating. The profile is protected by a passcode, and can only be changed by Overhead service representative. All settings are lost and reverted back to defaults when the profile is changed. Profiles can be accessed through the main menu under Profile Selection.

PART 4 LIMIT SETUP MENU

Individual limits can be updated manually, however; the best option is to use the quick setup process as discussed earlier. The door will not be operational when setting limits. Limit settings are as described below.

WARNING

ALL ENTRAPMENT PROTECTION DEVICES ARE OFF WHEN SETTING LIMITS. DEVICES OFF WHILE SETTING LIMITS INCLUDE: EDGE CONTACT, PHOTOEYE, WALL PUSH BUTTONS, RADIO CONTROL, LIMIT SENSORS, LOOP DETECTOR, OR ANY MOTION SENSOR USED AS EITHER AN ACTUATOR OR AN ENTRAPMENT PROTECTION DEVICE. ONLY THE INTERLOCK REMAINS ACTIVE. USE CAUTION! KEEP OPENINGS CLEAR OF PERSONS AND PROPERTY TO AVOID SERIOUS INJURY OR DEATH! DO NOT USE FOR GENERAL DOOR OPERATION WHEN SETTING LIMITS.

To configure the Limit Settings manually after using Quick Setup, select each individual position listed below from the Limit Setup menu, then move the door to the desired position. Store the position by pressing STOP or ENTER when finished. The display shows Stored and returns to the previous menu.

- Closed: Door fully closed.
- Pre Closed: Position where door changes to pre-closing speed during close.
- Pre Open: Position where door changes to pre-open speed during open.
- Open: Door fully closed.
- Open Part 1: Partially open position 1. Door opens to this position when a part 1 open input is active. (default: 75% of door open limit)
- Open Part 2: Partially open position 2. Door opens to this position when a part 2 open input is active. (default: 50% of door open limit)
- Rev. Edge OFF: Sets door position where safety edge check is turned off: the limit where the reversing safety edge should be ignored.
- Photocell Off: Sets door position where photocell should be ignored.

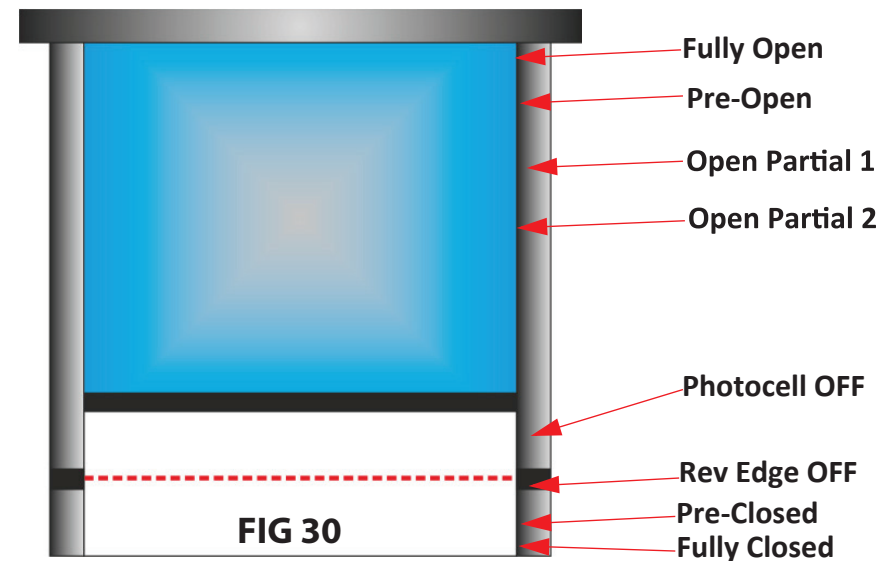

SECTION 7 - MENUS (continued.....)

PART 5 SYSTEM CONFIGURATION MENU

This menu contains all editable parameters on the door system. A passcode is required in order to change the settings. The door will not operate when inside the menu.

A. Timers

1. Contains all the same timers in the Express Menu.
2. Setting the timer to 0 disables the timer.

B. Outputs - Configurable relay activation based on custom door status/events. Table on pages 26-27 lists all available status/events.

C. Inputs - Inputs with configurable actuator functions. Table on pages 30-31 list all functions available with each input.

D. Position sensor -Do not update/menu is not used

E. Reference -Do not update/menu is not used.

F. Safety Edges -Do not update / Menu not used.

G. Photoeyes -Do not update/menu is not used

H. Motor Configuration - Do not update / Engineering use only.

I. Frequencies - Do not update / Tech Services use only.

J. Ramps - Do not update / Tech Services use only.

K. DG-XNET -Do not update / Menu not used.

L. Options -Menu to access the pairing of the wireless sensing edge host.

M. System -Do not update / Engineering use only.

CONFIGURATION INPUT/OUTPUTS

A. Inputs. There are 3 parameters that can be set. Refer to **FIG 31** (close up view of Input relays)

1. Function -A list of functions can be selected to determine how the input should operate the door.
2. Name -a name can be applied to the specific function
3. Logic -The logic for activation of the door can be chosen. Either Normally Open (0VDC ->24VDC) or Normally Closed (24VDC ->0VDC).

B. Outputs. Refer to **FIG 32** (close up view of Output relays)

1. Function -list of functions can be selected to activate the output relay
2. The output is dependent on the input wired into the relay pins 2, 5, 7, 9.
3. Output relays 1 & 2 consist of two relay outputs, a NO and NC. Output Relays 3 & 4 contain only NO relay activation.

SECTION 7 - MENUS (continued.....)

PART 5 SYSTEM CONFIGURATION MENU (continued.....)

INPUT SIGNAL	ACTIVATION DESCRIPTION
Manual	Momentary activation opens door unless the door is already at an open position. In this case, the door will close. 1) If the Manual timer is set to a value greater than zero, the controller delays closing of the door until the timer expires.
Open	Opens the door to fully open position when activated.
Auto 1	Momentary activation opens door to the fully open position limit. Upon deactivation the controller delays the door for the duration of the Auto timer. If reactivated during this time delay, the timer will be reset and will begin to decrement when the input is again deactivated. Upon expiration of the timer, the controller closes the door to fully closed position. If timer is not used, the door will stay in the open position when activated.
Stop	Momentary activation stops the motion of the door. This input uses the Stop Deceleration Ramp set under the System Config menu. This input is also used to clear certain error conditions.
Close	Closes the door to fully open position when activated
Emergency Stop	Activation immediately halts the door in motion. This input uses the Emergency Deceleration Ramp set under the System Config menu.
Safety Edge	Activation during a closing cycle stops the door and then reverses the door motion back to the fully open position limit. An "E10 Safety Edge Activated" error occurs.
Photoeye	Activation during a closing cycle stops the door and then reverses the door motion back to the fully open position limit.
Lock Open	Activation causes the controller to hold the door at the fully open position limit. The input must be continuously activated to maintain the locked open state. Deactivating this input unlocks the door and allows normal operation.
Lock Close	Activation causes the controller to hold the door at the fully closed position limit. The input must be continuously activated to maintain the locked open state. Deactivating this input unlocks the door and allows normal operation.
Open Jog	Activation of this input moves the door in the direction of the fully open limit at Jog speed. Deactivating this input stops the door in motion. Activation during closing does not open or stop the door.
Close Jog	Activation of this input moves the door in the direction of the fully closed limit at Jog speed. Deactivating this input stops the door in motion. Activation during opening does not close or stop the door.
Breakaway	Activation halts door motion.
Open Position 1	Activation opens the door to the partial open 1 position limit. If activated during closing, door will reverse to 1 position limit.
Open Position 2	Activation opens the door to the partial open 2 position limit. If activated during closing, door will reverse to 2 position limit.
Open Part 1 Auto	Activation opens the door to partial open 1 position limit. The controller then delays the door for the duration of the Auto Timer. Upon expiration of the timer, the door closes fully.
Open Part 2 Auto	Activation opens the door to partial open 2 position limit. The controller then delays the door for the duration of the Auto Timer. Upon expiration of the timer, the door closes fully.
Flip Flop	Activation reverses the door operation. If door is closed, activation opens the door and vice versa. When door is closing and activated, the door reverses and begins opening and vice versa.
Man Part 1	Activation opens the door to the partial open 1 position limit, if not already at this position. If the door is already at this position, the door closes.
Man Part 2	Activation opens the door to the partial open 2 position limit, if not already at this position. If the door is already at this position, the door closes.

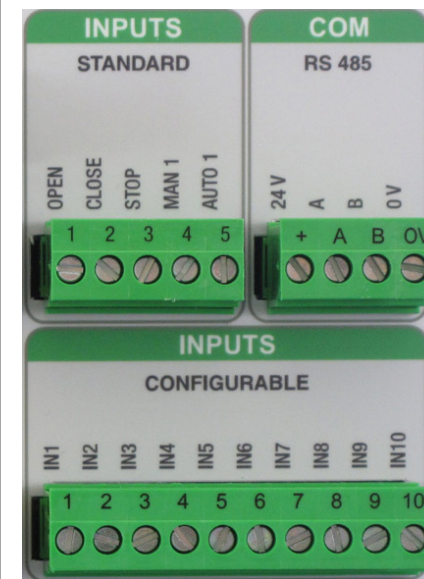

FIG 31

SECTION 7 - MENUS (continued.....)

PART 5 SYSTEM CONFIGURATION MENU (continued.....)

INPUT SIGNAL	ACTIVATION DESCRIPTION
Door Moving	Output is active when the door is in motion.
Door Not Moving	Output is active when the door is not in motion.
Door Open	Output is active when the door is at the fully open position.
Door Closed	Output is active when the door is at the fully closed position.
Door Not Closed	Output is active when the door is above the fully closed position.
Door Open Partial	Output is active when the door is at open part 1 position.
Door Opening	Output is active when the door is moving in the open direction.
Door Closing	Output is active when the door is moving in the close direction.
Delay to Close	Output is active when the Delay To Close timer is greater than zero and the door is commanded to close. The output remains active for the duration of the Delay To Close timer.
Delay to Open	Output is active when the Delay To Open timer is greater than zero and the door is commanded to open. The Open button must remain active until the Delay To Open timer has expired, the output will be active during this time. Upon expiration of the timer, the door opens and the output is deactivated.
Auto Close Active	Output is active for the duration of the Auto or Man timer during an auto close sequence.
System Error	Output is active when DGII is in any error condition.
Pre Warning Active	Output is active for the duration of the Auto Timer and during any close sequence.
Open Alarm Active	Output is active when Open Alarm Timer is greater then zero.

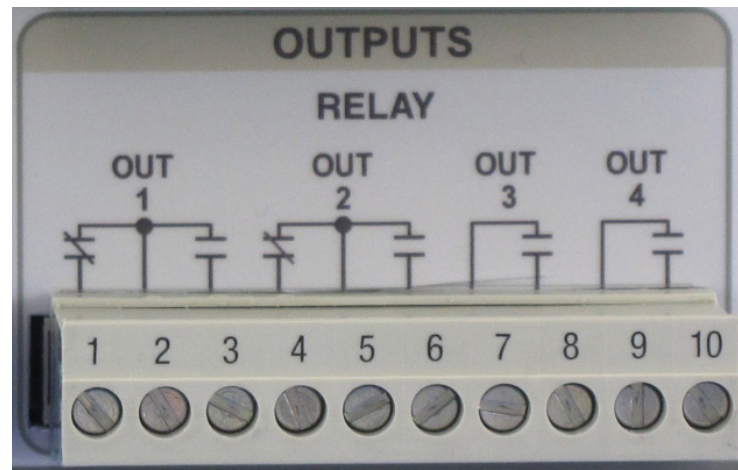

FIG 32

SECTION 7 - MENUS (continued.....)

PART 6 INFORMATION MENU

How to use the keypad to retrieve operation events, fault/shutdown messages, and system status (Also see **SECTION 8**—Troubleshooting)

- A. With the unit idle enter the System Status menu.
- B. Scroll through the list of choices until you reach the Fault Log menu and enter.
- C. Scroll through the list until you reach the information you're looking for.
- D. When finished exit the menus and return to the main screen.

NOTE: The items in the Fault Log are listed in reverse chronological order with number 1 being the most recent and the highest number being the oldest.

- If NO keys are pressed for 120 seconds, display will exit back to the main menu.
- Motion can occur and panel responds normally to inputs while in the System Status Menus.

FAULT LOG

Log 1 of 10

Error: E10

On Cycle: 045

PART 7 SETUP CHECK LIST

WARNING

CHECK ALL ITEMS BELOW TO ENSURE THAT THE CONTROL PANEL IS INSTALLED AND OPERATING PROPERLY AND ENTRAPMENT PROTECTION IS WORKING PROPERLY. A DOOR SYSTEM THAT IS NOT PROPERLY SETUP CAN CAUSE DEATH OR SERIOUS INJURY.

CHECK

- The door operates using all installed control devices.
- The door runs to its full open and full closed positions.
- The Entrapment Protection Device(s) will reverse a closing door when actuated.
- The proper Actuator selections are made to activate timers.
- The Hand Chain interlock switch prevents motor/door movement when the hand chain is pulled.

If the panel is in a location where public access is possible, install a means to limit access to the inside of the panel.

SECTION 8 - TROUBLESHOOTING THE CONTROLLER

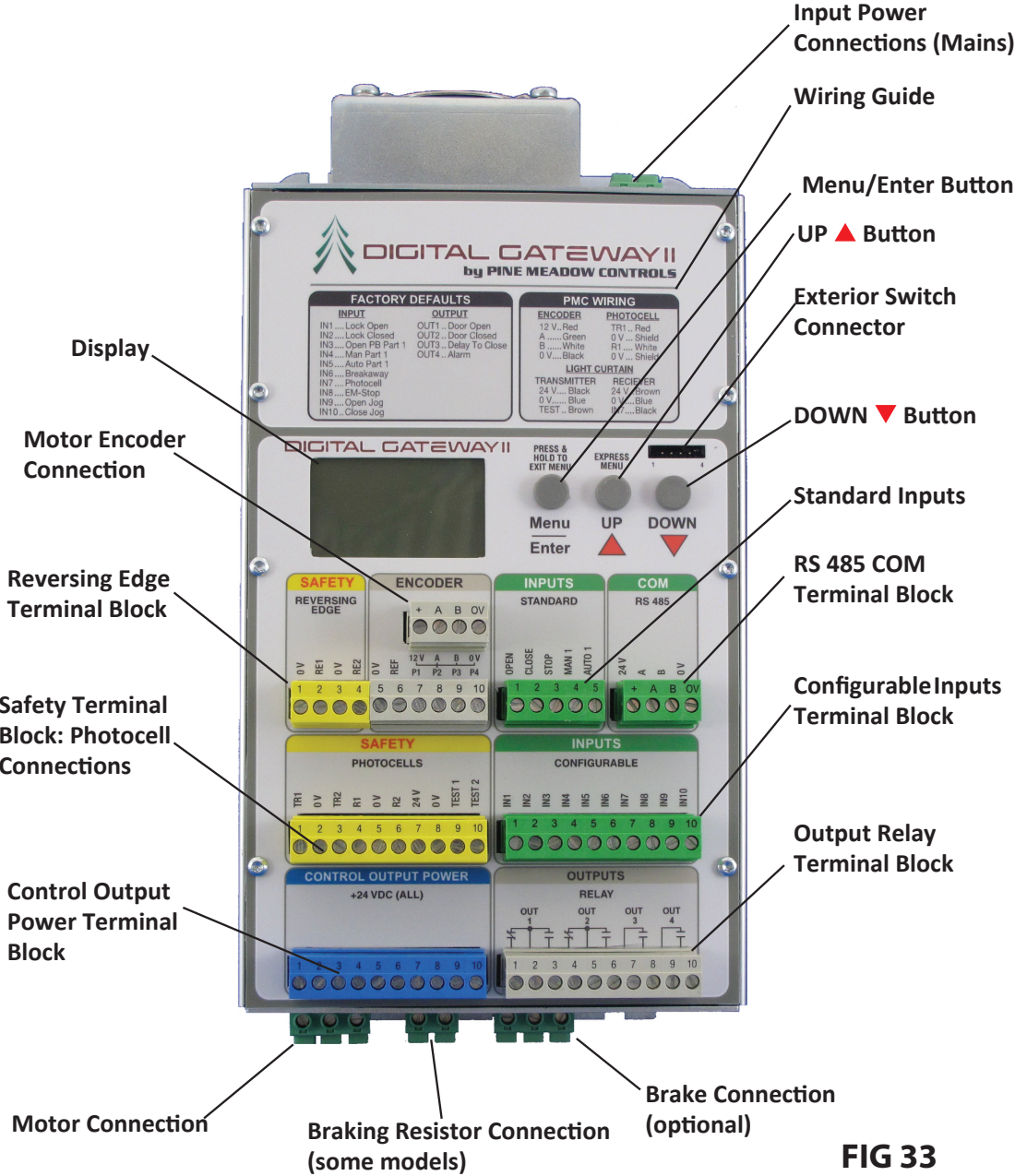

FIG 33

SECTION 8 - TROUBLESHOOTING THE CONTROLLER (contd.....)

PART 1 GENERAL TROUBLESHOOTING

TROUBLE	POTENTIAL CAUSE	NOTES / CORRECTIVE ACTION
Door will not move	Door may be in Shut Down mode. Fix issue.	Press stop key to clear fault.
	No power	Check motor wiring, power line, system rating.
Timed Close not functioning	Timer is set to 0.	Verify or update specific timer in express menu..
	Timer condition not met.	Verify door is at open close limits, or condition is met.
Auto 1/ Manual 1 Function not working	Wiring or connection loose, signal not reaching controller.	Verify connections.
	Auto 1/Man 1 not selected as function.	Verify chosen input function.
On key release, door stops or reverses	One of the sensor inputs activated.	Verify sensor inputs.
Timed Close quits after a few reverses	After a factory set number of failed attempts, usually three, the door will stop attempting to Time Close after a reversal. This is normal door function.	Door will reverse a Timed Closed door without counting the first reversal as a failed attempt. NOTE: If Entrapment Prevention Inputs cause reversals in the meantime, the reversals will continue to count as failed attempts and stop the close timer after three tries.
Wall push button not responding.	Wiring and firmware setting incorrect.	Common should be set to 24V Stop is set to NC in firmware (System config > Inputs) Open is set to NO. Close is set to NO. Refer to FIG 34 page 35
General service Due: XXXXX	Routine service interval has elapsed.	Contact distributor for required maintenance.
Major service Req'd XXXXX	Required maintenance interval has elapsed.	Contact distributor for required maintenance.
Door stops for no reason, or acts differently than before - No errors displayed, only shows IDLE at status	A brownout or short has affected the controller	Use the disconnect switch to turn off the power, wait until the unit shuts off, then turn it back on (hard reset). -Contact customer service if it is still an issue.
	Possible overheat	Check fault log
One of the options to the Junction Box does not operate as expected	Connection to the Junction Box is incorrect	Ensure the Junction Box connections are correct (Via Manual) 1. Radio Remote Receiver is wired to Manual1 input -A 10 kohm load is also needed to be wired from the Manual1 input to a 24VDC connection (part of the kit when delivered). 2. Loop Detector or Motion Detector is wired to Option 1 (or to an Auto1 input) NOTE* Both can be wired, but one needs to be wired directly to the Control Unit (regular wire can be used)
Quick setup aborted	Fault occurred when setting limits	1. Fix faults in system. 2. Make sure Position Sensor does not roll over from +32,000 to -32,000 when setting limits. 3. Make sure Position count increases when setting door to open limit (door direction incorrect). 4. Restart Quick Setup.
Door limits have shifted	Position Sensor fault/failure	1. Verify Position Sensor connections. 2. Verify magnet in position sensor has not moved and has not rubbed against the encoder. 3. Reset limits.

SECTION 8 - TROUBLESHOOTING THE CONTROLLER (contd....)

PART 2 CONTROL PANEL STATUS MESSAGES

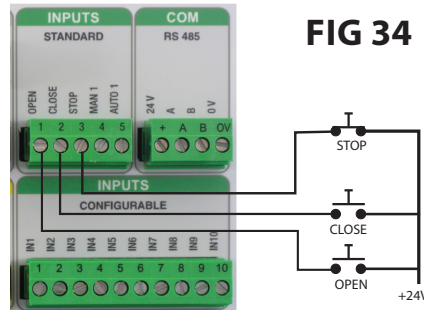

MESSAGE DISPLAYED	CAUSE	NOTES / CORRECTIVE ACTION
-----	Displayed if no message code is present in the Event or Error Log.	Contact service representative.
STATUS		
Idle	Door at rest, not at open, close, mid limits.	Displayed when door is motionless in Idle and not at open, close, open P1 limits. Door stopped using the STOP key.
STATUS		
Count down	Door at rest and counting down to timed close or open.	Time remaining in seconds is displayed.
STATUS - OPENING		
Opening	Door opening.	Displayed while door is opening from activation.
STATUS - CLOSING		
Closing	Door closing.	Displayed while door is closing from activation.
STATUS - STOP		
Stop	Door stopping.	Displayed while door is stopping from activation.
STATUS		
Locked	Incorrect pass code input.	Displayed when the wrong pass code is entered
Closed	Position at close limit.	
Open	Position at open limit.	
Open P1	Position at 75% of open limit.	
Open P2	Position at mid limit.	

SECTION 8 - TROUBLESHOOTING THE CONTROLLER (contd.....)

PART 3 CONTROL PANEL ERROR MESSAGES - INVERTER ERROR CODES

CODE	DESCRIPTION	PROBLEM	POSSIBLE SOLUTION
INV_ERROR_UU	DC Link low (Top Priority)	The incoming mains voltage is too low	View System Status - DC Link to check that the voltage is within the range shown.
INV_ERROR_OU	DC Link high (Medium Priority)	Either the incoming mains voltage is too high or the deceleration rate is too short	View System Status - DC Link to check that the voltage is within the range shown. Decrease the deceleration ramps.
INV_ERROR_OC1	Overcurrent 210% (Low Priority)	The motor current exceeds the inverter rating by 210%	View the Motor Current display to check the current delivered to the motor. Check the motor nameplate data to confirm that the correct controller model is being used. Check for mechanical obstruction or damage.
INV_ERROR_OC2	Overcurrent 150%/30 sec (Low Priority)	The motor current exceeds the inverter rating by 150% for more than 30 seconds	View the Motor Current display to see the current delivered to the motor. Check the motor nameplate data to confirm that the correct controller is being used. Check for mechanical obstruction or damage.
INV_ERROR_OC3	Overcurrent during acceleration	Overcurrent while accelerating	View the Motor Current display to see the current delivered to the motor. Decrease the acceleration ramps
INV_ERROR_OC4	Overcurrent DC/Brake (Medium Priority)	Overcurrent while DC braking	View the Motor Current display to see the current delivered to the motor. Decrease the DC Brake level.
INV_ERROR_OC5	Peak overcurrent (High Priority)	Severe overload	Check for: a short in the motor cable stalled motor mechanically or electrically damaged motor. If equipped with a parking brake, ensure that it is being released. Decrease the Boost parameters.
INV_ERROR_OH	Controller overheat (High Priority)	The inverter is overheated	View System Status - Temperature to check that the reported temperature is within range. Check ventilation and ensure fan, if present, is operating. Reset the controller and confirm that the fan operates for 1 second during the power-up routine. Reduce the duty cycle of the door.
INV_ERROR_12V	Low internal 12v (Top Priority)	The internal 12V DC power supply voltage is too low	View the System Status - Int Levels to check that the voltage is within range. Check I/O wiring for shorts.
INV_ERROR_24V	Low internal 24v (Top Priority)	The internal 24V DC power supply voltage is too low	View the System Status - Int Levels to check that the voltage is within range. Check I/O wiring for shorts.

SECTION 8 - TROUBLESHOOTING THE CONTROLLER (contd.....)

PART 4 CONTROL PANEL ERROR MESSAGES - DOOR CONTROL ERROR CODES

CODE	DESCRIPTION	PROBLEM	POSSIBLE SOLUTION
E01	Slip error (Low Priority)	Mechanical overload (Slip Monitoring) or missing signal from encoder.	Check door for obstruction. Ensure the pulse output from the encoder is connected to terminal P2 on the controller. Verify that the encoder pulse output is set correctly.
E02	Direction Error - occurs during setup only (Low Priority)	The direction of the motor is incorrect. The encoder count must increment positively while the door is moving in the open direction.	Use the Motor Direction parameter to set the correct direction for the motor and encoder.
E03	No Signal From Pulse Generator - occurs during setup only. (Low Priority)	No pulse input detected from the encoder.	Check door for obstruction. Ensure the pulse output from the encoder is connected to terminal P2 on the Controller. Verify that the encoder pulse output is set correctly.
E04	Speed Error	Door moves faster/slower than Expected	Check door for obstruction.
E05	N/A		
E06	N/A		
E07	Run Timer Exceeded (Low Priority)	The Run Timer has expired.	Check the Run Timer parameter to ensure a correct value.
E08	Safety Edge Test Fail (Medium Priority)	The Reversing Edge test has failed	Check the connections from the reversing edge to the controller. If using the Seywave wireless system, check operation of connected host and remote door sensor.
E09	Safety Edge Connection (Medium Priority)	The Reversing Edge connection cannot be verified.	Check the connections from the reversing edge to the controller. If using the Seywave wireless system, check operation of connected host and remote door sensor. Verify Safety edge is not activated.
E10	Safety Edge 1 Activated (Low Priority)	The Reversing Edge has been activated	Check for obstruction in door's path.
E11	Safety Edge 2 Activated (Low Priority)	The Reversing Edge has been activated	Check for obstruction in door's path.
E12	Lifting Force Exceeded (Low Priority)	The torque limit has been exceeded	If the torque limiting feature is being used, adjust the Torque Limit parameter to suit the application.
E13	No Encoder movement	Encoder did not move when expected	Check for obstruction. Check connection from Position Sensor to Motor.
E14	Absolute Encoder Comm Loss (Top Priority)	Communication with the absolute encoder has been lost.	Check the connections between the encoder and the controller.
E15	Installation Fault (Low Priority)	An error occurred during Quick Setup	Re-perform Quick Setup
E16	Encoder fault	Encoder communication is not correct	Check Position Sensor. Verify connections.

SECTION 8 - TROUBLESHOOTING THE CONTROLLER (continued.....)

PART 4 CONTROL PANEL ERROR MESSAGES - DOOR CONTROL ERROR CODES (continued.....)

CODE	DESCRIPTION	PROBLEM	POSSIBLE SOLUTION
E17	Reset Limits (HIGH PRIORITY)	The position limits cannot be verified	Perform a Quick Setup
E18	Wireless Airlock Failed to Authorize Opening (Low Priority)	The controller failed to receive an Airlock request acknowledgement.	Check opposite controller to ensure that it is operational. Check that both controllers have been wirelessly connected together and that each controller has Wireless and Airlock enabled. Disconnect controllers and run a discovery to reconnect controllers.
E19	Wireless No Response	There was no response from the onboard wireless	Ensure that the Wireless is Enabled then power cycle the controller.
E20	Backroll error	Door movement when at idle state	Verify there are no obstructions, verify motor gear box is functional.
E21	Option - Seywave OCS Remote Timeout	A paired Seywave wireless O/C/S remote has timed out.	Check the remote for operation. Refer to supplied Seywave Wireless manual for troubleshooting.
E22	Option - Seywave DS Remote Timeout	A paired Seywave wireless Door Sensor remote has timed out.	Check the remote for operation. Refer to supplied Seywave Wireless manual for troubleshooting.
E23	Option - Seywave DS Connection Fault	A paired Seywave wireless Door Sensor remote has reported a connection fault.	Check the connection and remote for operation. Refer to supplied Seywave Wireless manual for troubleshooting.
E24	N/A		
E25	Manual Crank input active (Medium Priority)	Manual Crank is off the Support Bracket	Put Hand Crank back on the Support Bracket.
E26	Overtravel error (HIGH PRIORITY)	Door moves beyond limits.	Reset limits
E27	Photoeye connection test fail (Medium Priority)	Monitored Photoeye connection test failed.	Check photoeye connections
E28	Photoeye 1 activation (Low Priority)	Photoeye 1 has detected an obstruction.	Check for obstructions in photoeye path
E29	Photoeye 2 activation (Low Priority)	Photoeye 2 has detected an obstruction	Check for obstructions in photoeye path
E30	Input Timer Exceeded	Input activation lasting longer than 2 minutes.	Verify wall buttons are not stuck. Check connections for a short.

PART 5 CONTROL PANEL ERROR MESSAGES - ERROR CODE PRIORITY LEVELS

Priority Level	Reset Condition	Comment
Low	Activation input	Can also be reset by higher priority reset conditions
Medium	Stop, E-Stop or Menu/Enter button pressed	Can also be reset by higher priority reset conditions
High	Menu/Enter button pressed and held for 2 seconds.	Screen Flashes
Priority Reset Limits	Successful Quick Setup	Auto-clears when limits are set
Priority Encoder Connection	Communication restored between encoder and controller	Auto-clears when fault no longer exists
Priority INV_ERROR_UU	Incoming main voltage is within range	Auto-clears when fault no longer exists
Priority INV_ERROR_12VInternal 12V	Internal 12V DC level is within range	Auto-clears when fault no longer exists
Priority INV_ERROR_24V	Internal 24V DC level is within range	Auto-clears when fault no longer exists

SECTION 9 - SERVICE AND MAINTENANCE

▲ WARNING

FAILURE TO PERFORM SPECIFIED SERVICE AND MAINTENANCE MAY RESULT IN AN UNSAFE CONDITION, WILL VOID LIMITED WARRANTY, AND MAY RESULT IN PREMATURE FAILURE OF THE UNIT. SERVICE AND MAINTENANCE ARE NECESSARY TO ENSURE SAFE OPERATION OF THE RAPIDFLEX® DOOR.

General Maintenance Interval Message

- Upon reaching 150,000 door cycles (300,000 & 450,000, etc.), the panel will display general maintenance needed.
- Contact your distributor to have required maintenance performed.
- Once service is completed, clear the service message by going into System Configuration ->System -> Clear Service.

Sensing Edge & Photoeye systems

- Test sensing edge activation daily.
 - Place a solid object, higher than 12", on floor and close door. Sensing edge should reverse door direction on contact with object.
- Test Photoeye activation daily.
 - Obstruct the Photoeye beam with a solid object. Photoeye should reverse door direction.

General Inspection

- Visually inspect wiring conduit and cables.
- Inspect fixtures such as: Bearings, conduit boxes, hood, gear box (for oil leakage), motor.
- Inspect safety labels, placement and condition.
- Lubricate guides with paste wax or silicone spray.

Manual Operation of Door

- Inspect door alignment and level.
- Inspect curtain and endlocks for damage.
- Inspect guides, sensing edge and hood for damage.

Mounting Bolt Tightness

- Check fasteners anchoring headplates and door guides to wall.

Check Limit Position

- Verify the door stops at correct open position.
- Verify that door closes fully without excessive "stacking" of curtain in guides.
- Verify approach speeds provide for smooth starts and stops.

Keep records of all service and maintenance.

INSTALLATION DATE: _____ INSTALLER INITIAL: _____
 SERVICE ITEM SERVICE INTERVAL (frequency)

SERVICE ITEM	SERVICE INTERVAL (frequency)		
	EVERY DAY	EVERY 6 MOS. OF 50,000 CYCLES	EVERY 12 MOS. OF 100,000 CYCLES
General Inspection		•	
Limit Switch Chain Tension and Alignment		•	
Manual Operation of Door		•	
Sensing Edge & Photo Eye systems	•		
Mounting Bolt Tightness			•
Motor Brake Gap and Motor			•
Check Limit Position		•	
Check Emergency Brake Activation List		•	

FIG 35

FIG 35 provides a schedule of Service and Maintenance items. To the right is a list of service and maintenance highlights.

SECTION 9 - SERVICE AND MAINTENANCE (continued....)

BREAKAWAY TAB RESET:

If the bottom bar breakaway tabs need resetting:

- Remove both the left and right hand front top guides.
- Using the jog function or the chain hoist, move the door all the way to the open position.
- Manually direct the breakaway tabs back into both the left and right hand guides.
- Make sure the door runs properly before re-installing both the left and right hand front top guides.

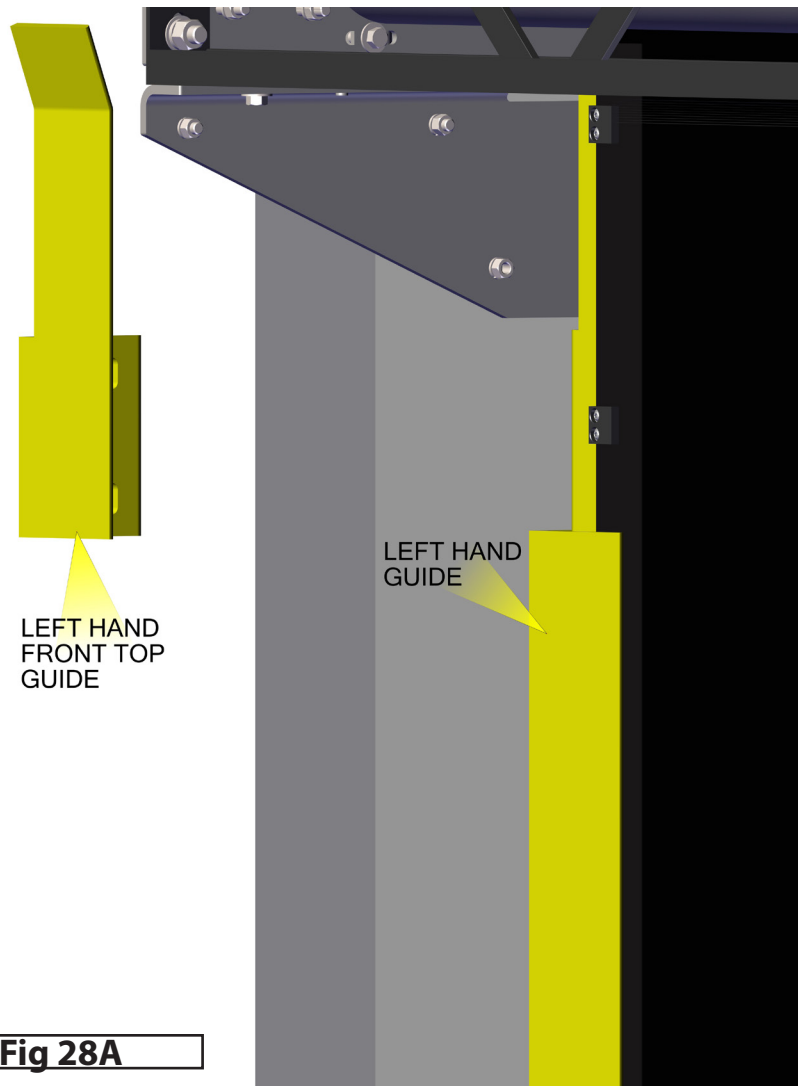

Fig 28A

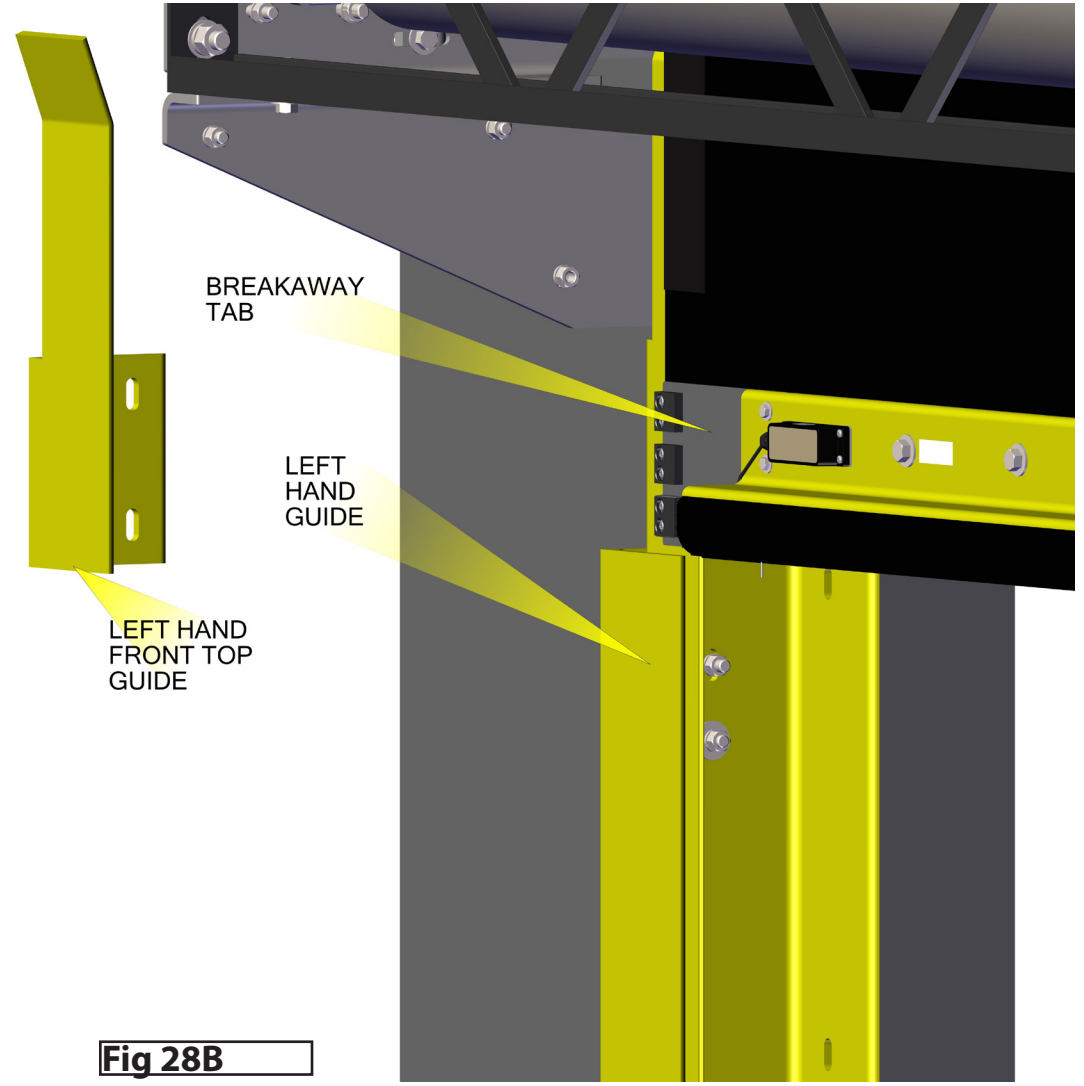

Fig 28B

The Genuine. The Original.



RapidFlex® and RapidFreeze™ High Speed Doors Limited Warranty

The Distributor of Overhead Door Corporation products whose name appears below ("Seller") warrants to the original purchaser of RapidFlex 990, 991, 992, 993, 994, and 995, 995LH series high speed fabric and rubber doors ("Product"), subject to all of the terms and conditions hereof, that the Product and all components thereof will be free from defects in materials and workmanship under normal use for the following period, measured from the date of installation:

- For RapidFlex® 991, 992, 993, 994, 995, 995LH and RapidFreeze™ 997, Seller warrants all mechanical door system components and the control panel hardware for a period of 60 MONTHS
- For RapidFlex® 990, Seller warrants the drive motor and gearbox system for a period of 60 MONTHS and Seller warrants all other components for a period of 12 MONTHS

Seller's obligation under this warranty is specifically limited to repairing or replacing, at its option, any part which is determined by Seller to be defective during the applicable warranty period. Repair or replacement labor for any defective Product part or component is included for a period of one (1) year from the date of installation. After that, any labor charges are excluded and will be the responsibility of the purchaser.

This warranty is made to the original purchaser of the Product only, and is not transferable or assignable. This warranty does not apply to any unauthorized alteration or repair of the Product, or to any Product or component which has been damaged or deteriorated due to misuse (including use of interior rated products in exterior applications), neglect, accident, failure to provide necessary maintenance, normal wear and tear, or acts of God or any other cause beyond the reasonable control of Seller. This warranty does not cover replacement batteries or apply to any damage, punctures or deterioration caused by door fabric and/or rubber curtain rubbing together as the door rolls up upon itself, or caused by exposure to salt water, chemical fumes or other corrosive or aggressive environments, whether naturally occurring or man-made, including, but not limited to, environments with a high degree of humidity, sand, dirt or grease.

THIS WARRANTY IS EXCLUSIVE AND IN LIEU OF ANY OTHER WARRANTIES, EITHER EXPRESS OR IMPLIED, INCLUDING BUT NOT LIMITED TO ANY IMPLIED WARRANTY OF MERCHANTABILITY OR FITNESS FOR A PARTICULAR PURPOSE.

IN NO EVENT SHALL OVERHEAD DOOR CORPORATION BE RESPONSIBLE FOR, OR LIABLE TO ANYONE FOR, SPECIAL, INDIRECT, COLLATERAL, PUNITIVE, INCIDENTAL OR CONSEQUENTIAL DAMAGES, even if Seller has been advised of the possibility of such damages. Such excluded damages include, but are not limited to, loss of goodwill, loss of profits, loss of use, cost of any substitute product, interruption of business, or other similar indirect financial loss.

Claims under this warranty must be made promptly after discovery, within the applicable warranty period, and in writing to the Seller or to the authorized distributor or installer whose name and address appear below. The purchaser must allow Seller a reasonable opportunity to inspect any Product claimed to be defective prior to removal or any alteration of its condition. Proof of the purchase and/or installation date, and identification as the original purchaser, may be required.

DOOR MODEL: _____

ORIGINAL PURCHASER: _____

INSTALLATION ADDRESS: _____

SELLER: _____

SELLER'S ADDRESS: _____

FACTORY ORDER #: _____

DATE OF INSTALLATION: _____

SIGNATURE OF SELLER: _____

C900-1058 05/25