

MODEL	STANDARD MAX. VALUES	
	WIDTH	HEIGHT
640	14'	11' 2"

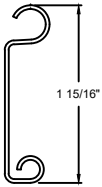

F158 SLAT SECTION

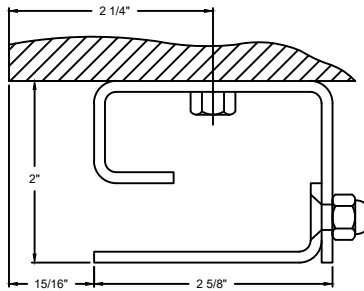

LARGE GUIDE DETAIL

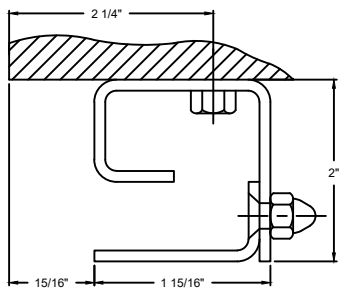

SMALL GUIDE DETAIL

OPTIONS

OPENING WIDTH	
OPENING HEIGHT	
HEADPLATE OPTIONS	<input type="checkbox"/> SMALL <input type="checkbox"/> LARGE
GUIDE OPTIONS	<input type="checkbox"/> SMALL <input type="checkbox"/> LARGE
FIRE DOOR EQUIPMENT OPTIONS	<input type="checkbox"/> FIRE SENTINEL (LH) <input type="checkbox"/> FIRE SENTINEL (RH) <input type="checkbox"/> HOOD FLAME BAFFLE <input type="checkbox"/> HORN & STROBE <input type="checkbox"/> KEYED TEST SWITCH (LH) <input type="checkbox"/> KEYED TEST SWITCH (RH) <input type="checkbox"/> SMOKE DETECTOR

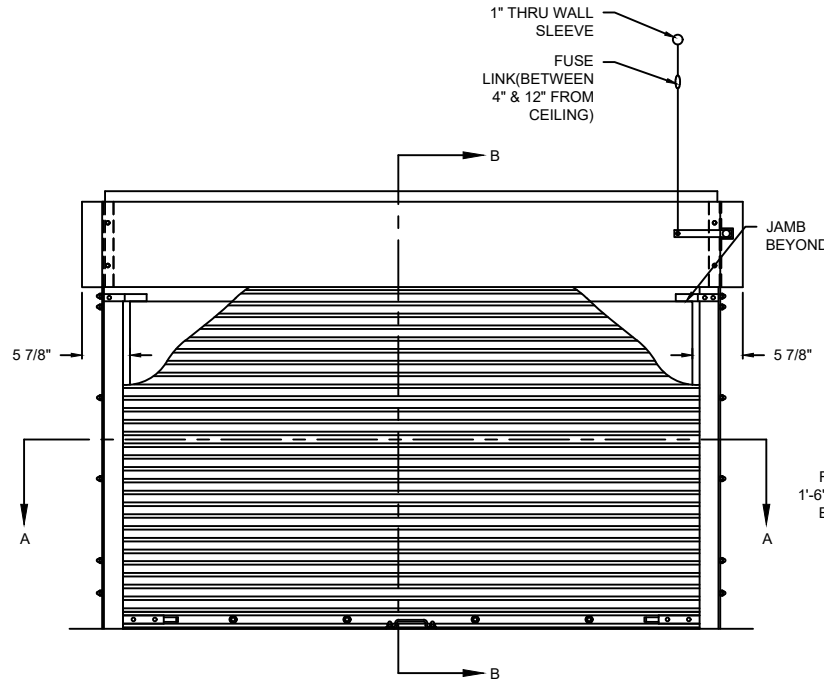

ELEVATION



OPENING WIDTH

COILSIDE

SECTION A-A

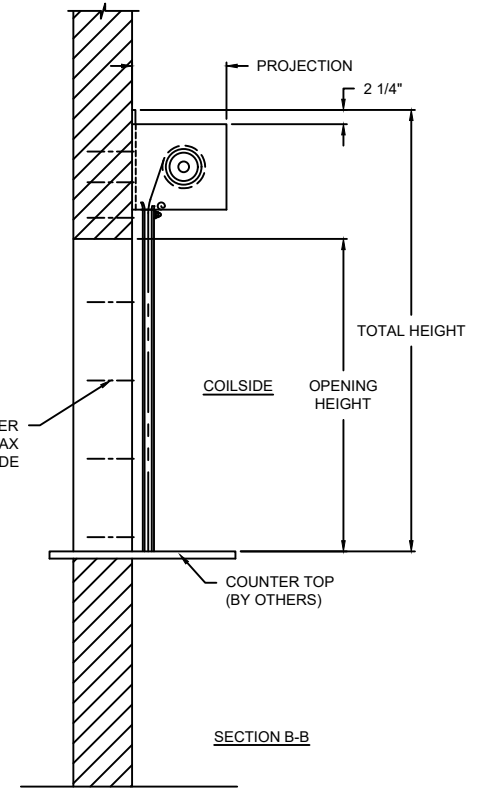

PROJECTION	
MIN.	MAX.
9.5" X 9.5"	11.5" X 11.5"

FIRE RATED COUNTER DOOR

640 FIRE RATED ROLLING COUNTER DOOR - FACE MOUNT

DWG. NO.	DATE:	
SHEET	BY:	

COMPONENT	MATERIAL	OPERATION	NOTES:
HOOD	24 GA. G40 GALV STEEL	MANUAL PUSH UP LH	- AVAILABLE WITH UL AND FM 3-HOUR (OPTIONAL) CLASS A LABELS FOR MASONRY FIRE WALLS - AVAILABLE WITH A UL 1 1/2-HOUR CLASS B LABEL FOR APPLICATIONS IN NON-MASONRY FIRE WALLS OF DRY WALL WITH WOOD, STEEL STUDS, OR STEEL TUBE JAMBS
CURTAIN	22 GA. G40 GALV STEEL		
GUIDES	11 GA. GRAY PRIMED STEEL		
BOTTOM BAR	G40 GALV STEEL		

MODEL	STANDARD MAX. VALUES	
	WIDTH	HEIGHT
640	14'	11' 2"

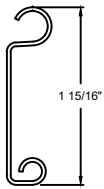

F158 SLAT SECTION

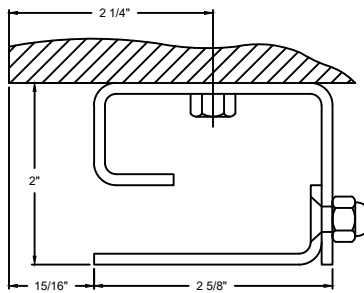

LARGE GUIDE DETAIL

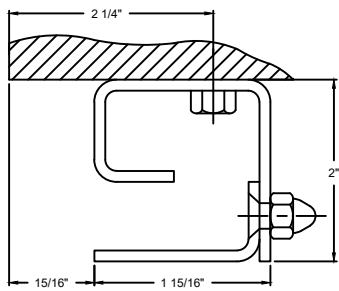

SMALL GUIDE DETAIL

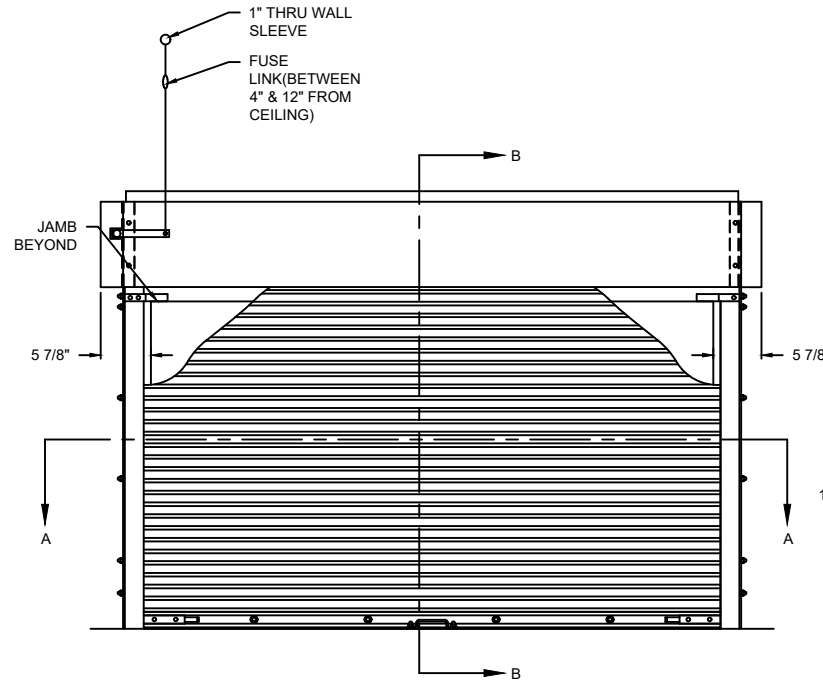

ELEVATION



COILSIDE

SECTION A-A

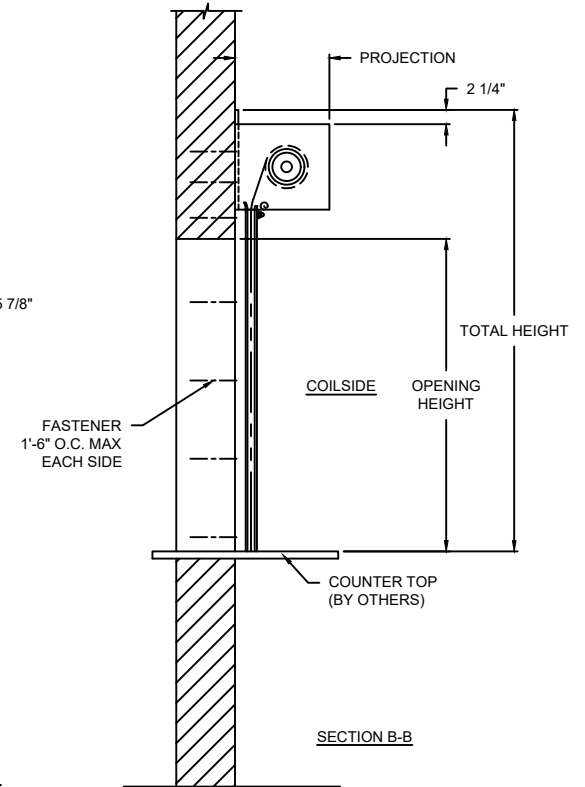

SECTION B-B

PROJECTION	
MIN.	MAX.
9.5" X 9.5"	11.5" X 11.5"

OPTIONS

OPENING WIDTH	
OPENING HEIGHT	
HEADPLATE OPTIONS	<input type="checkbox"/> SMALL <input type="checkbox"/> LARGE
GUIDE OPTIONS	<input type="checkbox"/> SMALL <input type="checkbox"/> LARGE
FIRE DOOR EQUIPMENT OPTIONS	<input type="checkbox"/> FIRE SENTINEL (LH) <input type="checkbox"/> FIRE SENTINEL (RH) <input type="checkbox"/> HOOD FLAME BAFFLE <input type="checkbox"/> HORN & STROBE <input type="checkbox"/> KEYED TEST SWITCH (LH) <input type="checkbox"/> KEYED TEST SWITCH (RH) <input type="checkbox"/> SMOKE DETECTOR

COMPONENT	MATERIAL	OPERATION	NOTES:
HOOD	24 GA. G40 GALV STEEL	MANUAL PUSH UP RH	- AVAILABLE WITH UL AND FM 3-HOUR (OPTIONAL) CLASS A LABELS FOR MASONRY FIRE WALLS - AVAILABLE WITH A UL 1½-HOUR CLASS B LABEL FOR APPLICATIONS IN NON-MASONRY FIRE WALLS OF DRY WALL WITH WOOD, STEEL STUDS, OR STEEL TUBE JAMBS
CURTAIN	22 GA. G40 GALV STEEL		
GUIDES	11 GA. GRAY PRIMED STEEL		
BOTTOM BAR	G40 GALV STEEL		

FIRE RATED COUNTER DOOR

640 FIRE RATED ROLLING COUNTER DOOR - FACE MOUNT

DWG. NO.	DATE:	
SHEET	BY:	

MODEL	STANDARD MAX. VALUES	
	WIDTH	HEIGHT
640	14'	11' 2"

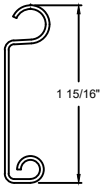

F158 SLAT SECTION

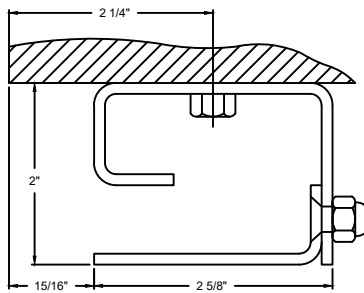

LARGE GUIDE DETAIL

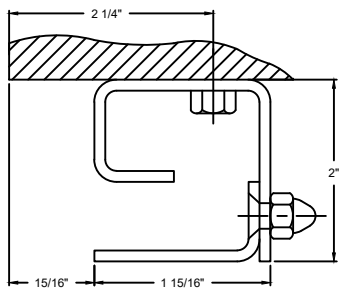

SMALL GUIDE DETAIL

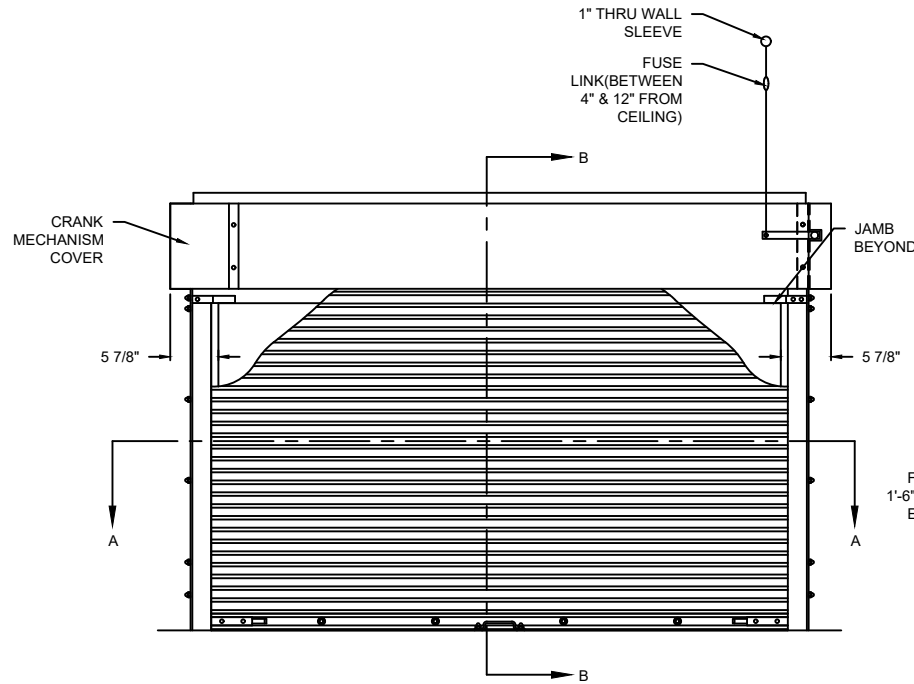

ELEVATION



COILSIDE

SECTION A-A

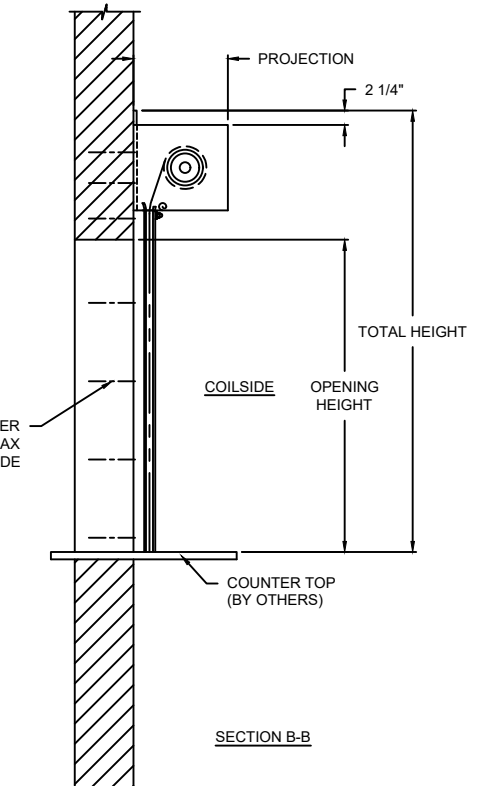

SECTION B-B

PROJECTION	
MIN.	MAX.
9.5" X 9.5"	11.5" X 11.5"

OPTIONS

OPENING WIDTH	
OPENING HEIGHT	
HEADPLATE OPTIONS	<input type="checkbox"/> SMALL <input type="checkbox"/> LARGE
GUIDE OPTIONS	<input type="checkbox"/> SMALL <input type="checkbox"/> LARGE
FIRE DOOR EQUIPMENT OPTIONS	<input type="checkbox"/> FIRE SENTINEL (LH) <input type="checkbox"/> FIRE SENTINEL (RH) <input type="checkbox"/> HOOD FLAME BAFFLE <input type="checkbox"/> HORN & STROBE <input type="checkbox"/> KEYED TEST SWITCH (LH) <input type="checkbox"/> KEYED TEST SWITCH (RH) <input type="checkbox"/> SMOKE DETECTOR

COMPONENT	MATERIAL	OPERATION	NOTES:
HOOD	24 GA. G40 GALV STEEL	CRANK LH	- AVAILABLE WITH UL AND FM 3-HOUR (OPTIONAL) CLASS A LABELS FOR MASONRY FIRE WALLS - AVAILABLE WITH A UL 1½-HOUR CLASS B LABEL FOR APPLICATIONS IN NON-MASONRY FIRE WALLS OF DRY WALL WITH WOOD, STEEL STUDS, OR STEEL TUBE JAMBS
CURTAIN	22 GA. G40 GALV STEEL		
GUIDES	11 GA. GRAY PRIMED STEEL		
BOTTOM BAR	G40 GALV STEEL		

FIRE RATED COUNTER DOOR

640 FIRE RATED ROLLING COUNTER DOOR - FACE MOUNT

DWG. NO.	DATE:	
SHEET	BY:	

MODEL	STANDARD MAX. VALUES	
	WIDTH	HEIGHT
640	14'	11' 2"

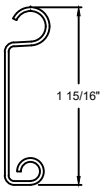

F158 SLAT SECTION

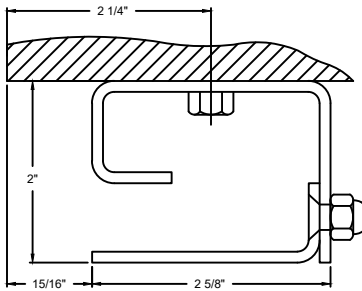

LARGE GUIDE DETAIL

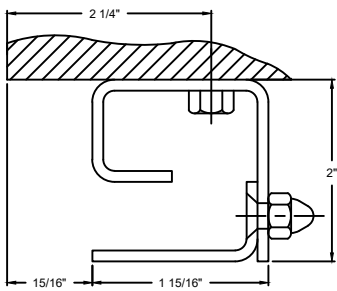

SMALL GUIDE DETAIL

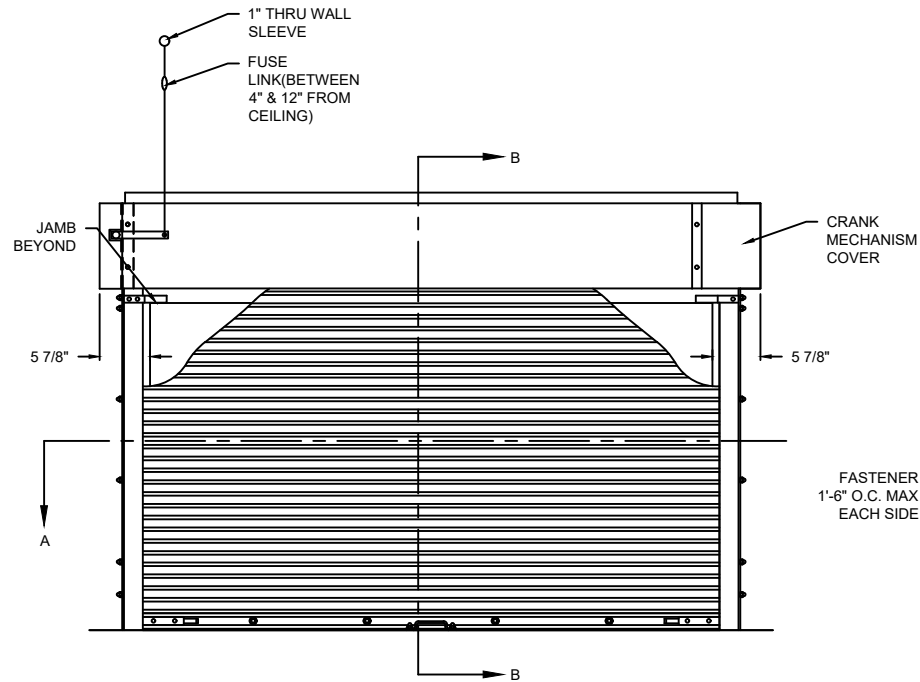

ELEVATION



COILSIDE

SECTION A-A

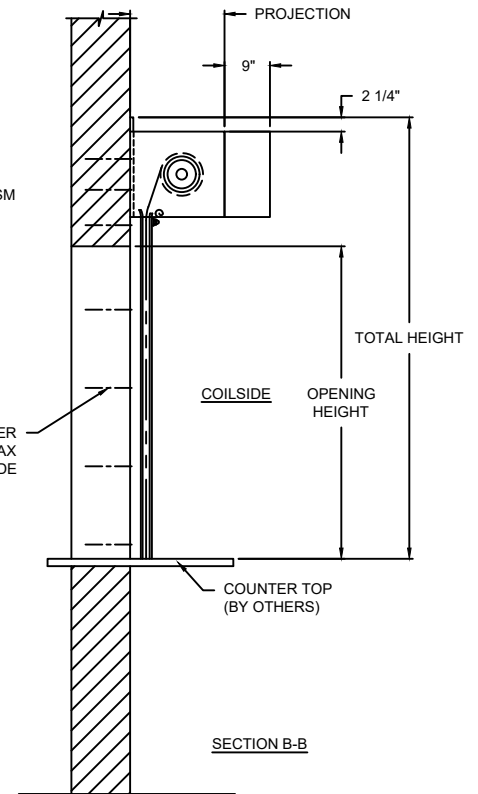

SECTION B-B

PROJECTION	
MIN.	MAX.
9.5" X 9.5"	11.5" X 11.5"

OPTIONS

OPENING WIDTH	
OPENING HEIGHT	
HEADPLATE OPTIONS	<input type="checkbox"/> SMALL <input type="checkbox"/> LARGE
GUIDE OPTIONS	<input type="checkbox"/> SMALL <input type="checkbox"/> LARGE
FIRE DOOR EQUIPMENT OPTIONS	<input type="checkbox"/> FIRE SENTINEL (LH) <input type="checkbox"/> FIRE SENTINEL (RH) <input type="checkbox"/> HOOD FLAME BAFFLE <input type="checkbox"/> HORN & STROBE <input type="checkbox"/> KEYED TEST SWITCH (LH) <input type="checkbox"/> KEYED TEST SWITCH (RH) <input type="checkbox"/> SMOKE DETECTOR

COMPONENT	MATERIAL	OPERATION	NOTES:
HOOD	24 GA. G40 GALV STEEL	CRANK RH	- AVAILABLE WITH UL AND FM 3-HOUR (OPTIONAL) CLASS A LABELS FOR MASONRY FIRE WALLS - AVAILABLE WITH A UL 1½-HOUR CLASS B LABEL FOR APPLICATIONS IN NON-MASONRY FIRE WALLS OF DRY WALL WITH WOOD, STEEL STUDS, OR STEEL TUBE JAMBS
CURTAIN	22 GA. G40 GALV STEEL		
GUIDES	11 GA. GRAY PRIMED STEEL		
BOTTOM BAR	G40 GALV STEEL		

FIRE RATED COUNTER DOOR

640 FIRE RATED ROLLING COUNTER DOOR - FACE MOUNT

DWG. NO.	DATE:	
SHEET	BY:	

MODEL	STANDARD MAX. VALUES	
	WIDTH	HEIGHT
640	14'	11' 2"

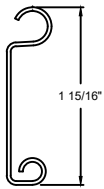

F158 SLAT SECTION

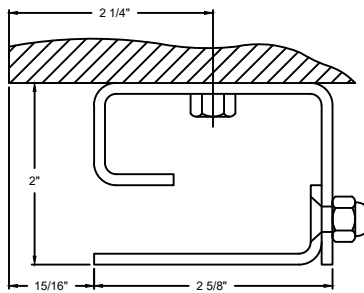

LARGE GUIDE DETAIL

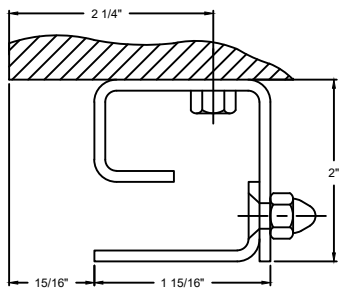

SMALL GUIDE DETAIL

OPTIONS

OPENING WIDTH	
OPENING HEIGHT	
HEADPLATE OPTIONS	<input type="checkbox"/> SMALL <input type="checkbox"/> LARGE
GUIDE OPTIONS	<input type="checkbox"/> SMALL <input type="checkbox"/> LARGE
FIRE DOOR EQUIPMENT OPTIONS	<input type="checkbox"/> FIRE SENTINEL (LH) <input type="checkbox"/> FIRE SENTINEL (RH) <input type="checkbox"/> HOOD FLAME BAFFLE <input type="checkbox"/> HORN & STROBE <input type="checkbox"/> KEYED TEST SWITCH (LH) <input type="checkbox"/> KEYED TEST SWITCH (RH) <input type="checkbox"/> SMOKE DETECTOR

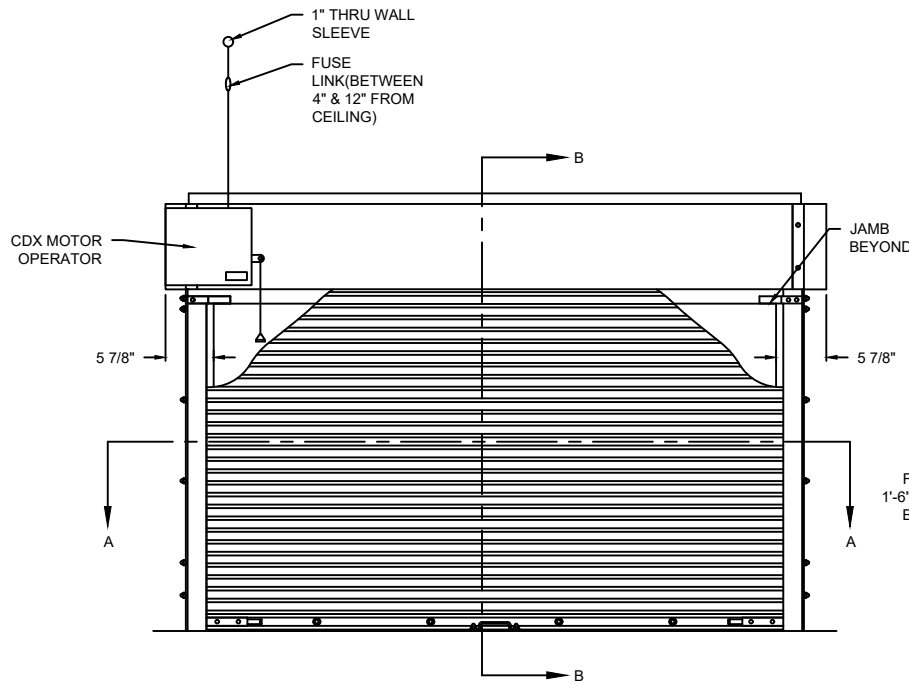

ELEVATION



COILSIDE

SECTION A-A

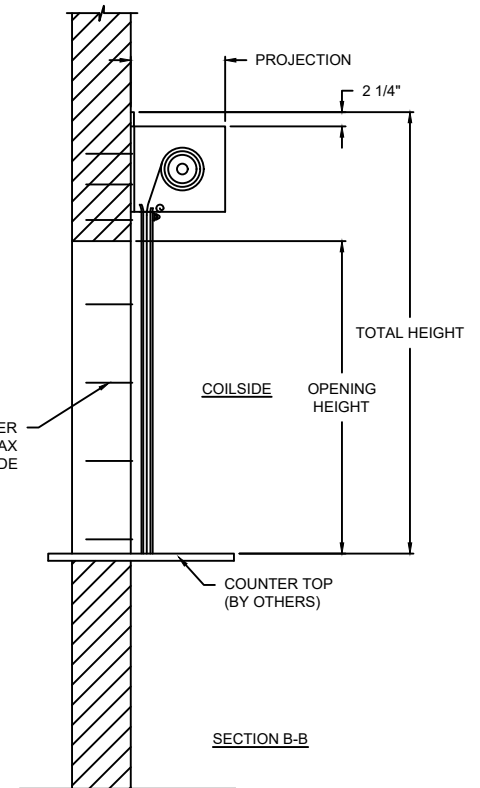

SECTION B-B

PROJECTION	
MIN.	MAX.
9.5" X 9.5"	11.5" X 11.5"

FIRE RATED COUNTER DOOR

640 FIRE RATED ROLLING COUNTER DOOR - FACE MOUNT

DWG. NO.	DATE:	The Genuine. The Original. OVERHEAD DOOR
SHEET	BY:	

COMPONENT	MATERIAL	OPERATION	NOTES:
HOOD	24 GA. G40 GALV STEEL	CDX OPERATOR LH	- AVAILABLE WITH UL AND FM 3-HOUR (OPTIONAL) CLASS A LABELS FOR MASONRY FIRE WALLS - AVAILABLE WITH A UL 1 1/2-HOUR CLASS B LABEL FOR APPLICATIONS IN NON-MASONRY FIRE WALLS OF DRY WALL WITH WOOD, STEEL STUDS, OR STEEL TUBE JAMBS
CURTAIN	22 GA. G40 GALV STEEL		
GUIDES	11 GA. GRAY PRIMED STEEL		
BOTTOM BAR	G40 GALV STEEL		

MODEL	STANDARD MAX. VALUES	
	WIDTH	HEIGHT
640	14'	11' 2"

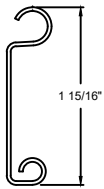

F158 SLAT SECTION

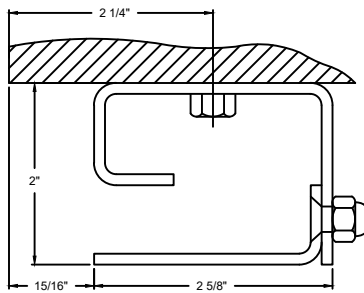

LARGE GUIDE DETAIL

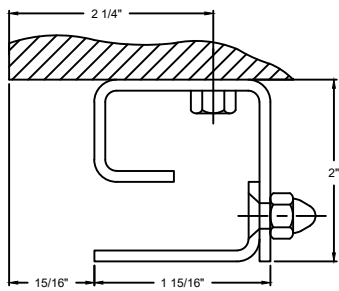

SMALL GUIDE DETAIL

OPTIONS

OPENING WIDTH	
OPENING HEIGHT	
HEADPLATE OPTIONS	<input type="checkbox"/> SMALL <input type="checkbox"/> LARGE
GUIDE OPTIONS	<input type="checkbox"/> SMALL <input type="checkbox"/> LARGE
FIRE DOOR EQUIPMENT OPTIONS	<input type="checkbox"/> FIRE SENTINEL (LH) <input type="checkbox"/> FIRE SENTINEL (RH) <input type="checkbox"/> HOOD FLAME BAFFLE <input type="checkbox"/> HORN & STROBE <input type="checkbox"/> KEYED TEST SWITCH (LH) <input type="checkbox"/> KEYED TEST SWITCH (RH) <input type="checkbox"/> SMOKE DETECTOR

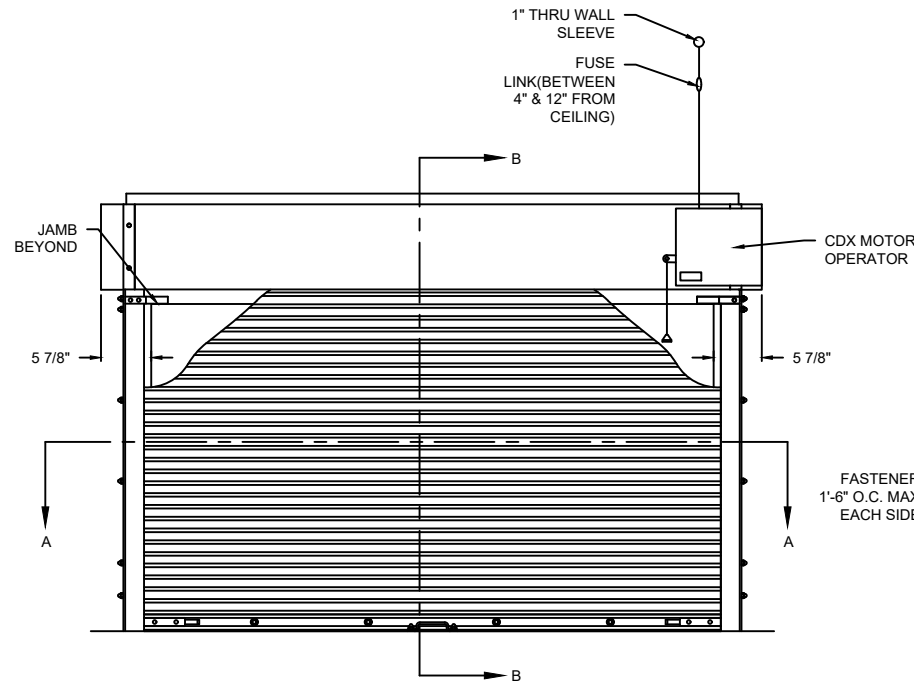

ELEVATION



COILSIDE

SECTION A-A

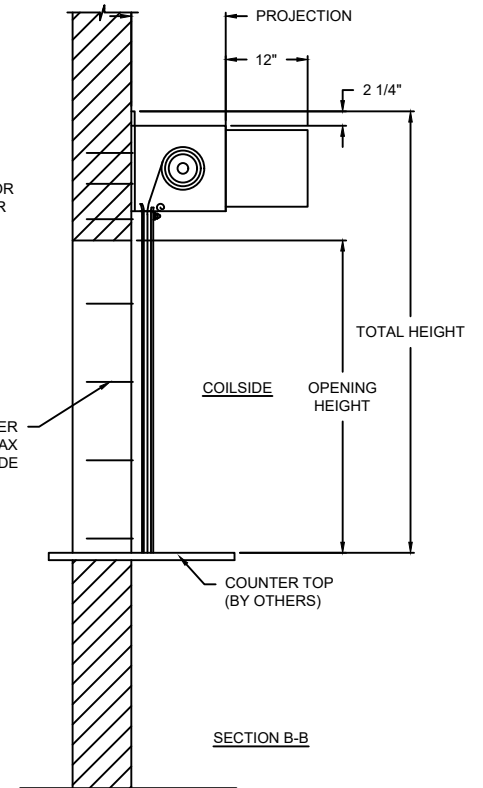

SECTION B-B

PROJECTION	
MIN.	MAX.
9.5" X 9.5"	11.5" X 11.5"

FIRE RATED COUNTER DOOR

640 FIRE RATED ROLLING COUNTER DOOR - FACE MOUNT

DWG. NO.	DATE:	
SHEET	BY:	

COMPONENT	MATERIAL	OPERATION	NOTES:
HOOD	24 GA. G40 GALV STEEL	CDX OPERATOR RH	- AVAILABLE WITH UL AND FM 3-HOUR (OPTIONAL) CLASS A LABELS FOR MASONRY FIRE WALLS - AVAILABLE WITH A UL 1 1/2-HOUR CLASS B LABEL FOR APPLICATIONS IN NON-MASONRY FIRE WALLS OF DRY WALL WITH WOOD, STEEL STUDS, OR STEEL TUBE JAMBS
CURTAIN	22 GA. G40 GALV STEEL		
GUIDES	11 GA. GRAY PRIMED STEEL		
BOTTOM BAR	G40 GALV STEEL		